

MASTER series

Quiet and weight-optimized
cable carriers



Trademarks are legally protected for the TSUBAKI KABELSCHLEPP GmbH as a national or international registration in the following countries:
tsubaki-kabelschlepp.com/Trademarks

Subject to change.

MASTER series | Overview

MASTER
series

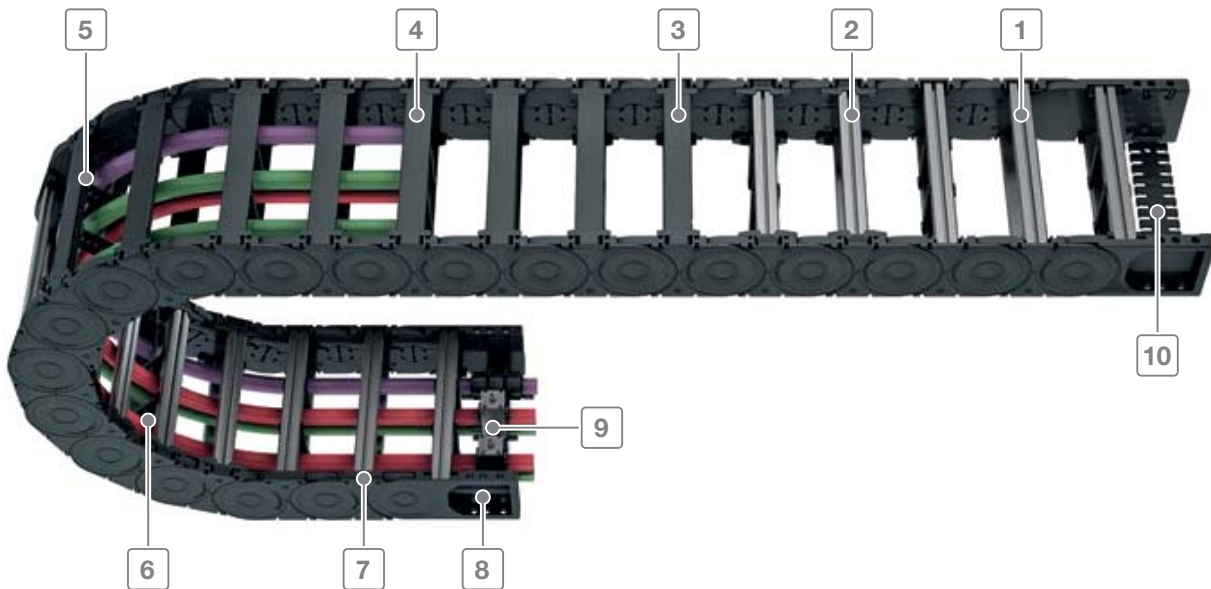

Inner heights



Inner widths



- 1** Aluminum stays available in **1 mm width sections**
- 2** Aluminum stays in **1 mm width sections** with plastic adapter
- 3** Plastic stays with integrated divider fixing
- 4** Can be opened quickly on the inside and the outside for cable laying
- 5** Fixable dividers
- 6** Many possibilities for internal subdivision
- 7** Replaceable glide shoes
- 8** Closed and open universal mounting brackets (UMBs)
- 9** C-rail for strain relief elements
- 10** Integratable strain relief comb

tsubaki-kabelschlepp.com/master

Features

- Low intrinsic weight
- Favorable ratio of inner to outer dimensions
- Versions with aluminum stays available in 1 mm width sections up to 800 mm inner width
- Long service life due to minimized hinge wear owing to the “life extending 2 disc principle”
- Extremely quiet through internal damping system
- Variable pre-tensioning for the most varied applications is possible

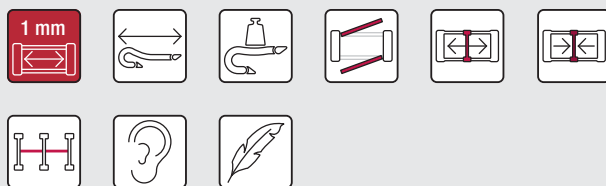

Minimized hinge wear owing to the “life extending 2 disc principle”



C-rail integrated in the connector



Fixable dividers for applications laying on the side and high lateral accelerations



Many separation options for the cables





















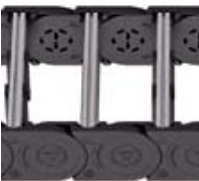

MASTER series | Overview

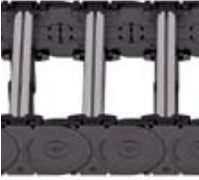
Key for abbreviations
on page 16

Design guidelines
from page 64

Technical support:
technik@kabelschlepp.de

 **online-engineer.de**
Cable Carrier Configurator

Type	Opening variant	Stay variant	h_i [mm]	h_G [mm]	B_i [mm]	B_k [mm]	B_i - grid [mm]	t [mm]	KR [mm]	Additional load \leq [kg/m]	Cable- d_{max} [mm]
											
H33											
		RSH	33	51	50–400	$B_i + 22$	1	56	60–300	11	26
H46											
		RSH	46	64	50–400	$B_i + 26$	1	67	75–350	20	36
L60											
		RSH	60	88	75–600	$B_i + 28$	1	91	135–500	20	48
		RE	60	88	85–250	$B_i + 28$	–	91	135–500	20	48
L80											
		RSH	80	110	100–800	$B_i + 32$	1	111	150–500	25	64
		RE	80	110	85–250	$B_i + 32$	–	111	150–500	25	64

MASTER series | Overview

Unsupported arrangement			Gliding arrangement			Inner distribution				Installation variants			Page
Travel length ≤ [m]	v_{max} ≤ [m/s]	a_{max} ≤ [m/s ²]	Travel length ≤ [m]	v_{max} ≤ [m/s]	a_{max} ≤ [m/s ²]	TS0	TS1	TS2	TS3	vertical hanging or standing	lying on the side	rotating arrangement	
3.5	10	50	60	2	2-3	●	●	–	●	●	●	–	310
6.4	8	40	80	2	2-3	●	●	–	●	●	●	–	316
7	6	30	–	–	–	●	●	–	●	●	●	–	322
7	6	30	–	–	–	●	●	–	●	●	●	–	326
7.9	5	25	–	–	–	●	●	–	●	●	●	–	332
7.9	5	25	–	–	–	●	●	–	●	●	●	–	336

Inner heights

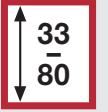

Inner widths



tsubaki-kabelschlepp.com/
master

H33

Key for abbreviations
on page 16

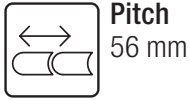

Pitch
56 mm

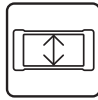

Inner height
33 mm

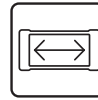

Inner widths
50 – 400 mm

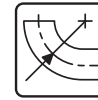

Bending radii
60 – 300 mm

Stay variants



Aluminum stay RSH page 310

Frame screw-in stay

- Aluminum profile bars for light to medium loads. Assembly without screws.
- **Outside/inside:** release by rotating 90°.

Design guidelines
from page 64

Technical support:
technik@kabelschlepp.de

online-engineer.de
Cable Carrier Configurator



TOTALTRAX® complete systems

Benefit from the advantages of the TOTALTRAX® complete system. A complete delivery from one source – with a warranty certificate on request! Learn more at tsubaki-kabelschlepp.com/totaltrax



TRAXLINE® cables for cable carriers

Hi-flex electric cables which were especially developed, optimized and tested for use in cable carriers can be found at traxline.de

Unsupported arrangement

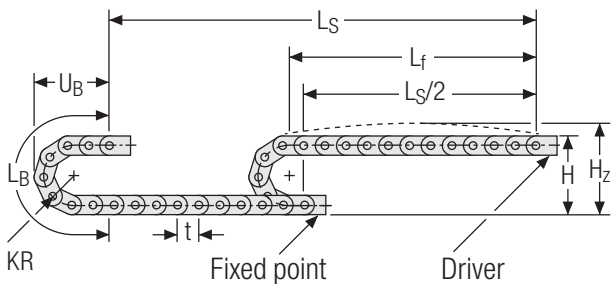

KR [mm]	H [mm]	H _z [mm]	L _B [mm]	U _B [mm]
60	171	211	301	142
75	201	241	348	157
100	251	291	427	182
125	301	341	505	207
150	351	391	584	232
175	401	441	662	257
200	451	491	741	282
220	491	531	804	302
250	551	591	898	332
300	651	691	1055	382

Inner heights



Inner widths



Load diagram for unsupported length depending on the additional load.

Sagging of the cable carrier is technically permitted for extended travel lengths, depending on the specific application.

Intrinsic cable carrier weight $q_k = 2.08 \text{ kg/m}$. For other inner widths, the maximum additional load changes.

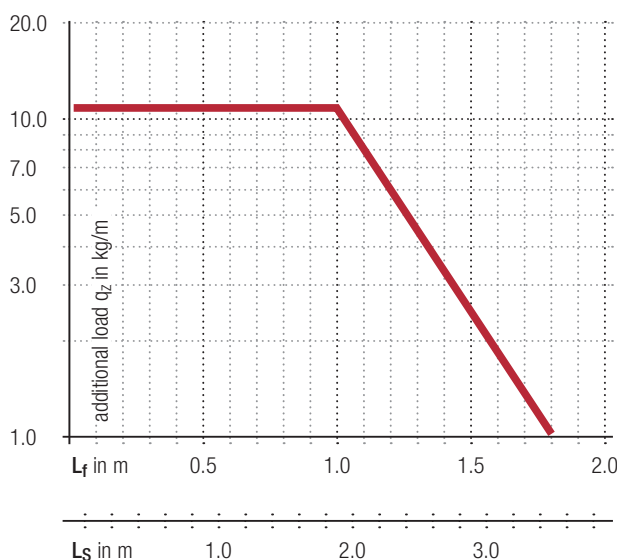

Speed
up to 10 m/s

Acceleration
up to 50 m/s²

Travel length
up to 3.5 m

Additional load
up to 11 kg/m

Gliding arrangement

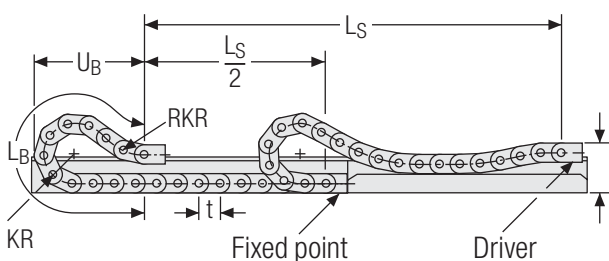

The gliding cable carrier must be guided in a channel. See p. 782.

We recommend the use of glide shoes for gliding applications.

Speed
up to 2 m/s

Acceleration
up to 2 - 3 m/s²

Travel length
up to 60 m

Additional load
up to 11 kg/m

HC33 RSH | Dimensions · Technical data

Aluminum stay RSH – screw-in frame stay

- Aluminum profile bars for light and medium loads. Assembly without screws.
- Available customized in **1 mm grid**.
- **Outside/inside:** release by rotating.



Key for abbreviations on page 16



Stays mounted on each chain link (**VS: fully-stayed**)



1 mm B_i 50 – 400 mm in **1 mm width sections**

Design guidelines from page 64

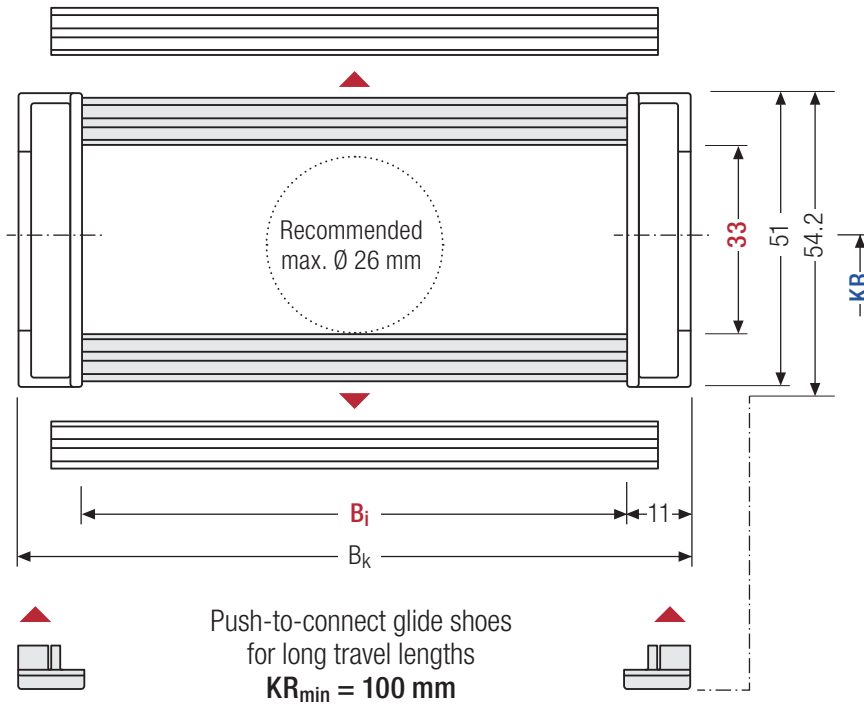

The maximum cable diameter strongly depends on the bending radius and the desired cable type. Please contact us.

Calculating the cable carrier length

Cable carrier length L_k

$$L_k \approx \frac{L_S}{2} + L_B$$

Cable carrier length L_k rounded to pitch t

Technical support: technik@kabelschlepp.de

h _i [mm]	h _G [mm]	h _{G'} [mm]	B _i [mm]*	B _k [mm]	KR [mm]										q _k [kg/m]
33	51	54,2	50 – 400	B _i + 22	60	75	100	125	150	175	200	220	250	300	1,37 – 3,99

* in 1 mm width sections

Order example



HC 33
Type

330
B_i [mm]

RSH
Stay variant

150
KR [mm]

1960
L_k [mm]

VS
Stay arrangement

Divider systems

The divider system is mounted on every 2nd chain link as a standard.

As a standard, dividers or the complete divider system (dividers with height separations) are movable in the cross section (**version A**).

For applications with lateral acceleration and lying on the side, the dividers can be attached by simple insertion of a fixing profile into the RSH stay, available as an accessory (**version B**).

Inner heights



Inner widths



Increments



Divider system TS0 without height separation

Vers.	a_T min [mm]	a_x min [mm]	a_c min [mm]	a_x grid [mm]	n_T min
A	7	13	10	—	—
B	7	13	10	2	—

The dividers can be moved within the cross section (version A) or fixed (version B).

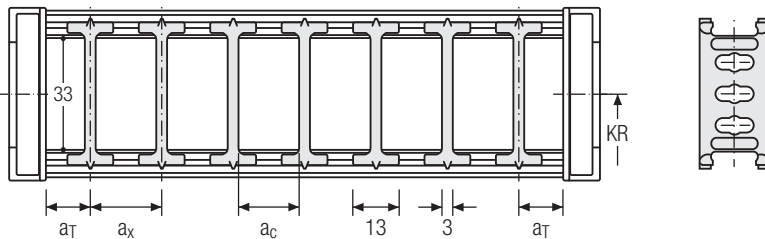

Divider system TS1 with continuous height separation

Vers.	a_T min [mm]	a_x min [mm]	a_c min [mm]	a_x grid [mm]	n_T min
A	7	13	10	—	2
B	7	13	10	2	2

The dividers can be moved within the cross section (version A) or fixed (version B).

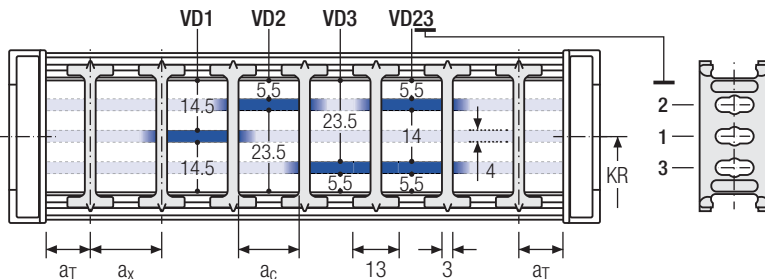

Divider system TS3 with height separation consisting of plastic partitions

Vers.	a_T min [mm]	a_x min [mm]	a_c min [mm]	n_T min
A	4	16	8	2

The dividers are fixed by the height separation, the complete divider system is movable in the cross section.

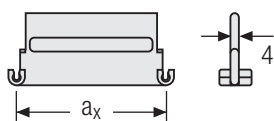
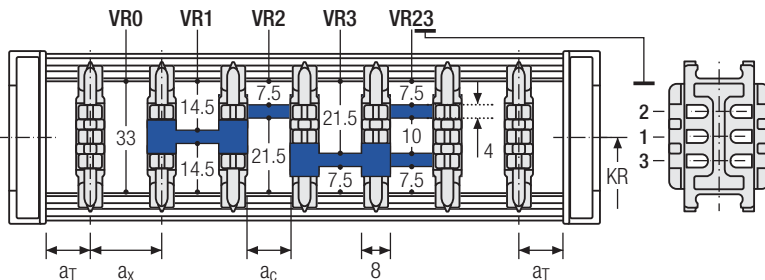

Aluminum partitions in 1 mm increments with $a_x > 42$ mm are also available.

a_x (center distance of dividers) [mm]											
a_c (nominal width of inner chamber) [mm]											
16	18	23	28	32	33	38	43	48	58	64	68
8	10	15	20	24	25	30	35	40	50	56	60
78	80	88	96	112	128	144	160	176	192	208	
70	72	80	88	104	120	136	152	168	184	200	

When using **plastic partitions with $a_x > 112$ mm**, we recommend an additional center support with a **twin divider** ($S_T = 3$ mm). Twin dividers are also suitable for retrofitting in the partition system.

H33 | End connectors

Universal end connectors UMB – plastic (standard)

The universal mounting brackets (UMB) are made from plastic and can be mounted **from the top, from the bottom or face on**.

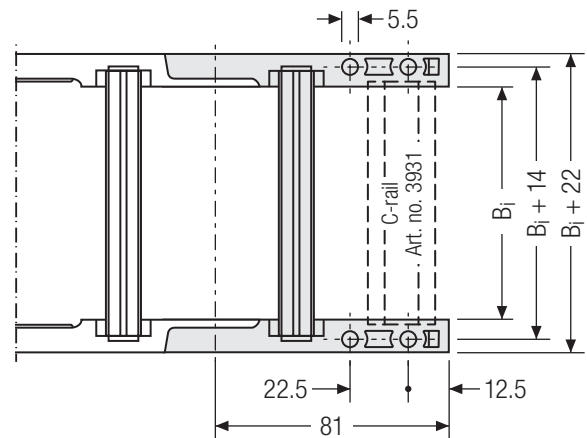
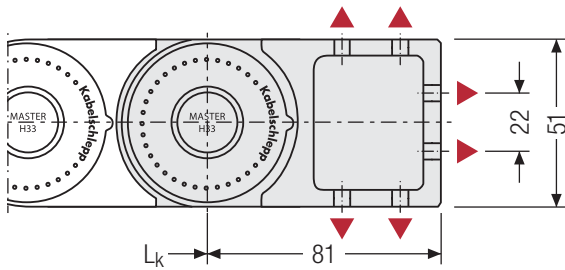

▲ Assembly options

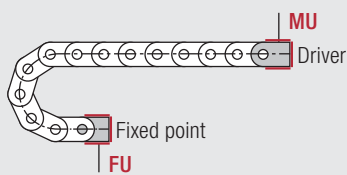

Connection point

- F** – fixed point
- M** – driver

Connection type

- U** – universal mounting bracket

Order example

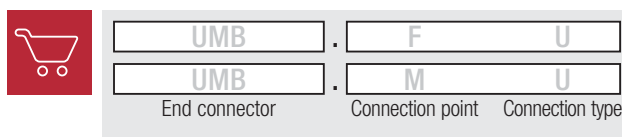

We recommend the use of strain reliefs before driver and fixed point. See from p. 834.

More product information online



Assembly instructions etc.:
Additional info via your
smartphone or check online at
[tsubaki-kabelschlepp.com/
support](http://tsubaki-kabelschlepp.com/support)



Configure your
cable carrier here:
onlineengineer.de

Key for abbreviations
on page 16

Design guidelines
from page 64

Technical support:
technik@kabelschlepp.de

online-engineer.de
Cable Carrier Configurator



MASTER
series

Inner
heights



Inner
widths



Incre-
ments



[tsubaki-kabelschlepp.com/
master](http://tsubaki-kabelschlepp.com/master)

H46

Key for abbreviations
on page 16

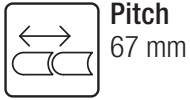

Pitch
67 mm

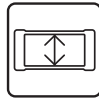

Inner height
46 mm

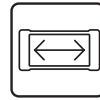

Inner widths
50 – 400 mm

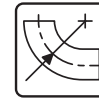

Bending radii
75 – 350 mm

Stay variants

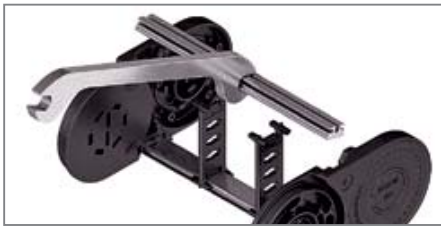

Aluminum stay RSH page 316

Frame screw-in stay

- Aluminum profile bars for light to medium loads.
Assembly without screws.
- **Outside/inside:** release by rotating 90°.

Design guidelines
from page 64

Technical support:
technik@kabelschlepp.de

online-engineer.de
Cable Carrier Configurator



TOTALTRAX® complete systems

Benefit from the advantages of the TOTALTRAX® complete system. A complete delivery from one source – with a warranty certificate on request! Learn more at tsubaki-kabelschlepp.com/totaltrax



TRAXLINE® cables for cable carriers

Hi-flex electric cables which were especially developed, optimized and tested for use in cable carriers can be found at traxline.de

H46 | Installation dim. | Unsupported

Unsupported arrangement

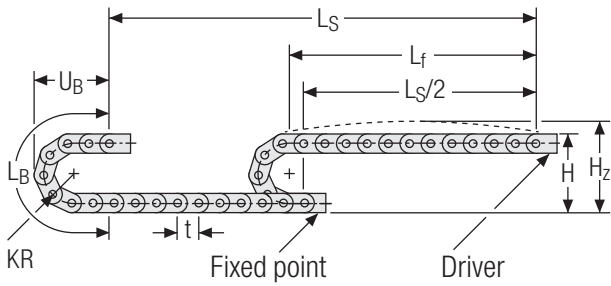

KR [mm]	H [mm]	H _z [mm]	L _B [mm]	U _B [mm]
75	214	262	370	174
100	264	312	448	199
125	314	362	527	224
150	364	412	605	249
175	414	462	684	274
200	464	512	762	299
220	504	552	825	319
250	564	612	919	349
300	664	712	1076	399
350	764	812	1234	449

Inner heights



Inner widths



Load diagram for unsupported length depending on the additional load.

Sagging of the cable carrier is technically permitted for extended travel lengths, depending on the specific application.

Intrinsic cable carrier weight $q_k = 2.4 \text{ kg/m}$. For other inner widths, the maximum additional load changes.

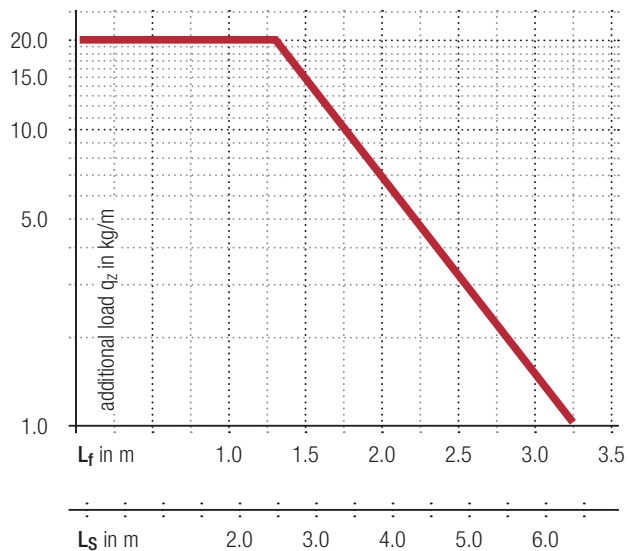

Speed
up to 8 m/s

Acceleration
up to 40 m/s²

Travel length
up to 6.4 m

Additional load
up to 20 kg/m

Gliding arrangement

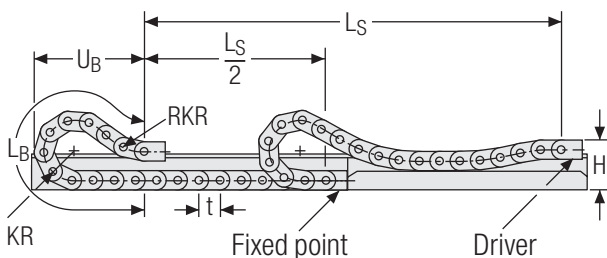

The gliding cable carrier must be guided in a channel. See p. 782.

We recommend the use of glide shoes for gliding applications.

Speed
up to 2 m/s

Acceleration
up to 2 – 3 m/s²

Travel length
up to 80 m

Additional load
up to 20 kg/m

HC46 RSH | Dimensions · Technical data

Aluminum stay RSH – screw-in frame stay

- Aluminum profile bars for light and medium loads. Assembly without screws.
- Available customized in **1 mm grid**.
- **Outside/inside:** release by rotating.



Key for abbreviations on page 16



Stays mounted on each chain link (**VS: fully-stayed**)



1 mm B_i 50 – 400 mm in **1 mm width sections**

Design guidelines from page 64

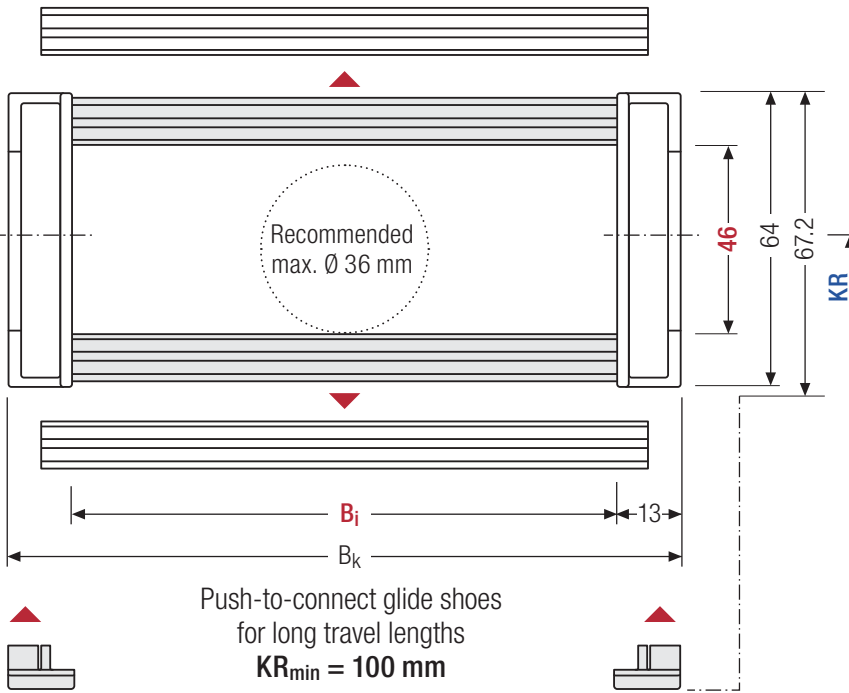

i The maximum cable diameter strongly depends on the bending radius and the desired cable type. Please contact us.

Calculating the cable carrier length

Cable carrier length L_k

$$L_k \approx \frac{L_S}{2} + L_B$$

Cable carrier length L_k rounded to pitch t

Technical support: technik@kabelschlepp.de

h _i [mm]	h _G [mm]	h _{G'} [mm]	B _i [mm]*	B _k [mm]	KR [mm]										q _k [kg/m]
46	64	67,2	50 – 400	B _i + 26	75	100	125	150	175	200	220	250	300	350	1,83 – 4,01

* in 1 mm width sections

Order example

HC 46 Type 200 B_i [mm] RSH Stay variant 170 KR [mm] 2010 L_k [mm] VS Stay arrangement

Divider systems

The divider system is mounted on every 2nd chain link as a standard.

As a standard, dividers or the complete divider system (dividers with height separations) are movable in the cross section (**version A**).

For applications with lateral acceleration and lying on the side, the dividers can be attached by simple insertion of a fixing profile into the RSH stay, available as an accessory (**version B**).

Inner heights

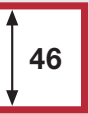

Inner widths



Increments



Divider system TS0 without height separation

Vers.	a_T min [mm]	a_x min [mm]	a_c min [mm]	a_x grid [mm]	n_T min
A	7	13	10	—	—
B	7	13	10	2	—

The dividers can be moved within the cross section (version A) or fixed (version B).

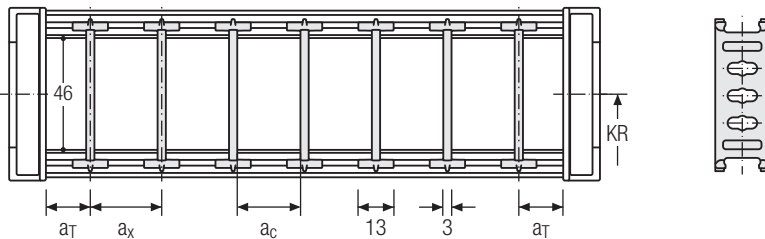

Divider system TS1 with continuous height separation

Vers.	a_T min [mm]	a_x min [mm]	a_c min [mm]	a_x grid [mm]	n_T min
A	7	13	10	—	2
B	7	13	10	2	2

The dividers can be moved within the cross section (version A) or fixed (version B).

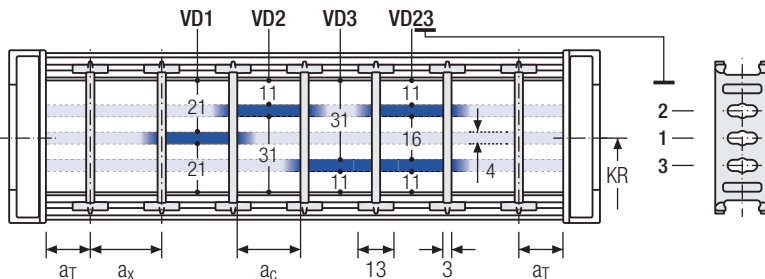

Divider system TS3 with height separation consisting of plastic partitions

Vers.	a_T min [mm]	a_x min [mm]	a_c min [mm]	n_T min
A	4	16	8	2

The dividers are fixed by the partitions, the complete divider system is movable in the cross section.

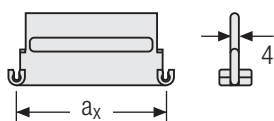
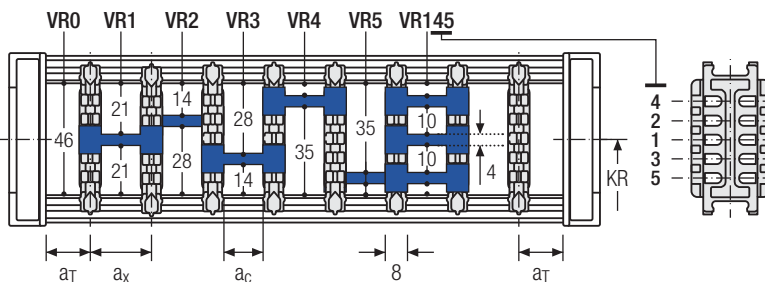

Aluminum partitions in 1 mm increments with $a_x > 42$ mm are also available.

a_x (center distance of dividers) [mm]											
a_c (nominal width of inner chamber) [mm]											
16	18	23	28	32	33	38	43	48	58	64	68
8	10	15	20	24	25	30	35	40	50	56	60
78	80	88	96	112	128	144	160	176	192	208	
70	72	80	88	104	120	136	152	168	184	200	

When using **plastic partitions with $a_x > 112$ mm**, we recommend an additional center support with a **twin divider** ($S_T = 3$ mm). Twin dividers are also suitable for retrofitting in the partition system.

H46 | End connectors

Universal end connectors UMB – plastic (standard)

The universal mounting brackets (UMB) are made from plastic and can be mounted **from the top, from the bottom or face on**.

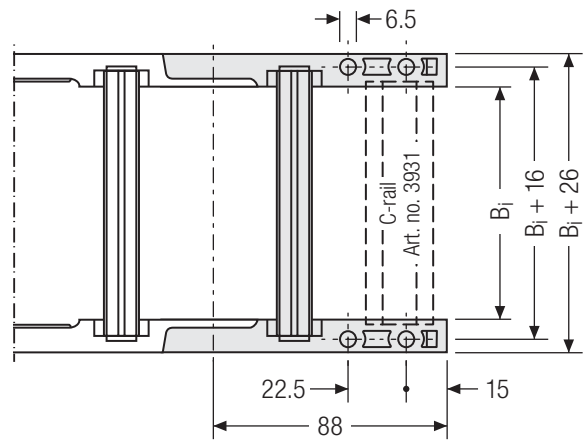
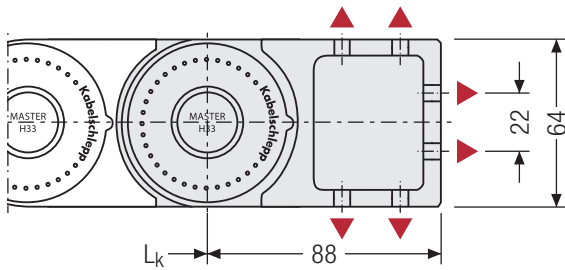

▲ Assembly options

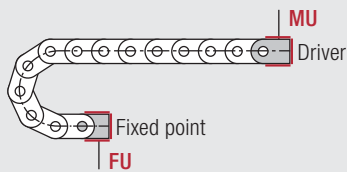

Connection point

- F** – fixed point
- M** – driver

Connection type

- U** – universal mounting bracket

Order example

	UMB	.	F	U
	UMB	.	M	U
	End connector		Connection point	Connection type



We recommend the use of strain reliefs before driver and fixed point. See from p. 834.

More product information online



Assembly instructions etc.:
Additional info via your
smartphone or check online at
[tsubaki-kabelschlepp.com/
support](http://tsubaki-kabelschlepp.com/support)



Configure your
cable carrier here:
onlineengineer.de

Key for abbreviations
on page 16

Design guidelines
from page 64

Technical support:
technik@kabelschlepp.de

online-engineer.de
Cable Carrier Configurator



Subject to change.

MASTER series

Inner heights

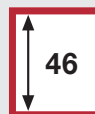

Inner widths



Increments



[tsubaki-kabelschlepp.com/
master](http://tsubaki-kabelschlepp.com/master)

L60

Key for abbreviations
on page 16



Pitch
91 mm



Inner height
60 mm

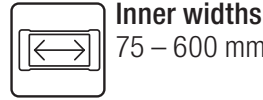

Inner widths
75 – 600 mm

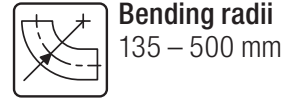

Bending radii
135 – 500 mm

Design guidelines
from page 64

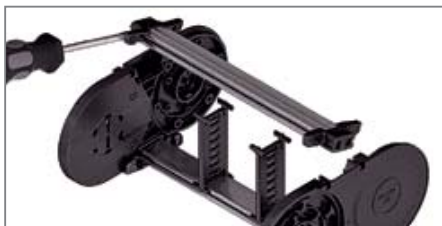

Aluminum stay RSH page 322

Frame screw-in stay

- Aluminum profile bars for light to medium loads.
Assembly without screws.
- **Outside/inside:** release by rotating 90°.

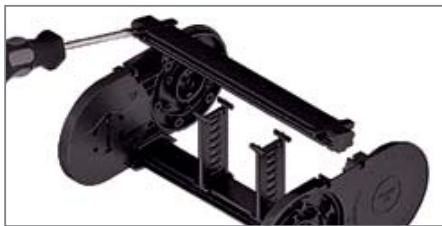

Plastic stay RE page 326

Frame screw-in stay

- Plastic profile bars for light to medium loads.
Assembly without screws.
- **Outside/inside:** release by rotating 90°.

Technical support:
technik@kabelschlepp.de



TOTALTRAX® complete systems

Benefit from the advantages of the TOTALTRAX® complete system. A complete delivery from one source – with a warranty certificate on request! Learn more at tsubaki-kabelschlepp.com/totaltrax



TRAXLINE® cables for cable carriers

Hi-flex electric cables which were especially developed, optimized and tested for use in cable carriers can be found at traxline.de

L60 | Installation dim. | Unsupported

Unsupported arrangement

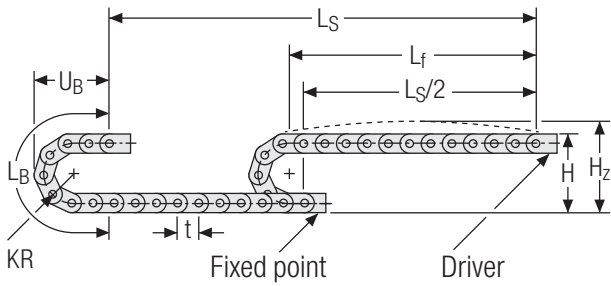

KR [mm]	H [mm]	H _z [mm]	L _B [mm]	U _B [mm]
135	358	408	607	271
150	388	438	654	286
175	441	491	732	312
200	488	538	811	336
250	588	638	968	386
300	688	738	1125	436
350	788	838	1282	486
400	888	938	1439	536
500	1088	1138	1753	636

Inner heights



Inner widths



Load diagram for unsupported length depending on the additional load.

Sagging of the cable carrier is technically permitted for extended travel lengths, depending on the specific application.

Intrinsic cable carrier weight $q_k = 3.6 \text{ kg/m}$. For other inner widths, the maximum additional load changes.

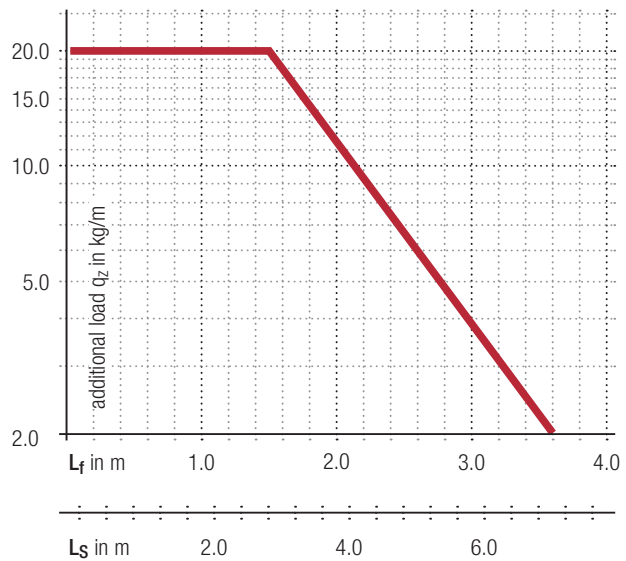

Speed
up to 6 m/s

Acceleration
up to 30 m/s²

Travel length
up to 7 m

Additional load
up to 20 kg/m

tsubaki-kabelschlepp.com/
master

More product information online



Assembly instructions etc.:
Additional info via your
smartphone or check online at
[tsubaki-kabelschlepp.com/
support](http://tsubaki-kabelschlepp.com/support)



Configure your
cable carrier here:
online-engineer.de

LC60 RSH | Dimensions · Technical data

Plastic stay RSH – screw-in frame stay

- Aluminum profile bars for light to medium loads. Assembly without screws.
- Available customized in **1 mm grid**.
- **Outside/inside:** release by rotating.



Key for abbreviations on page 16

Design guidelines from page 64

Technical support: technik@kabelschlepp.de



Stays mounted on each chain link (**VS: fully-stayed**)



1 mm B_i 75 – 600 mm in **1 mm width sections**

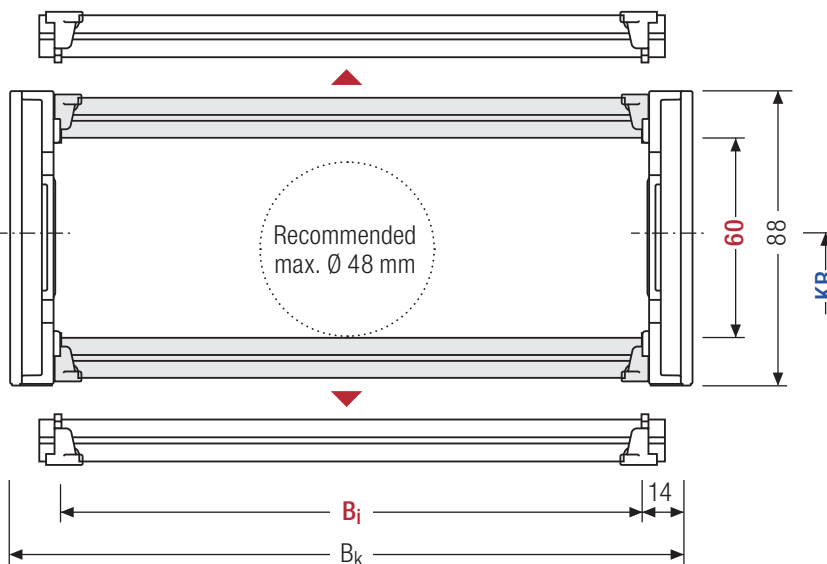

The maximum cable diameter strongly depends on the bending radius and the desired cable type. Please contact us.

Calculating the cable carrier length

Cable carrier length L_k

$$L_k \approx \frac{L_s}{2} + L_B$$

Cable carrier length L_k rounded to pitch t

h _i [mm]	h _g [mm]	B _i [mm]*	B _k [mm]	KR [mm]								q _k [kg/m]	
60	88	75 – 600	B _i + 28	135	150	175	200	250	300	350	400	500	2,78 – 7,10

* in 1 mm width sections

Order example



LC 60 . **400** . **RSH** . **250** - **2184**
Type B_i [mm] Stay variant KR [mm] L_k [mm]

VS
Stay arrangement

Divider systems

The divider system is mounted on every 2nd chain link as a standard.

As a standard, dividers or the complete divider system (dividers with height separations) are movable in the cross section (**version A**).

For applications with lateral acceleration and lying on the side, the dividers can be attached by a fixing profile, available as an accessory (**version B**). The fixing profile must be installed at the factory.

Inner heights



Inner widths



Increments



Divider system TSO without height separation

Vers.	a_T min [mm]	a_x min [mm]	a_c min [mm]	a_x grid [mm]	n_T min
A	10	13	9	—	—
B	10	13	9	2	—

The dividers can be moved within the cross section (version A) or fixed (version B).

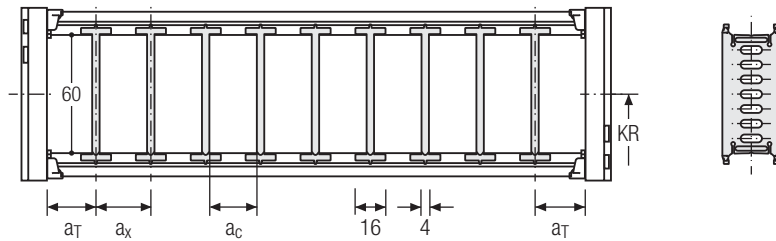

Divider system TS1 with continuous height separation

Vers.	a_T min [mm]	a_x min [mm]	a_c min [mm]	a_x grid [mm]	n_T min
A	10	13	9	—	2
B	10	13	9	2	2

The dividers can be moved within the cross section (version A) or fixed (version B).

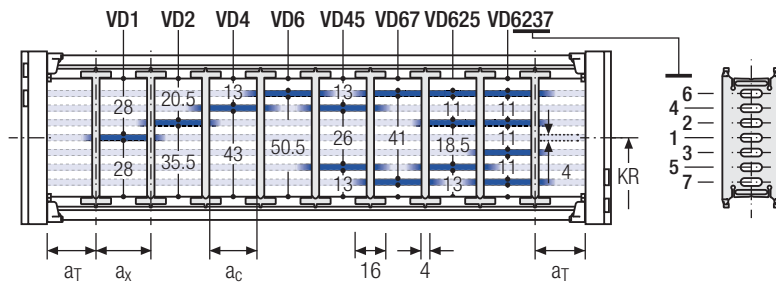

tsubaki-kabelschlepp.com/
master



TOTALTRAX® complete systems

Benefit from the advantages of the TOTALTRAX® complete system. A complete delivery from one source – with a warranty certificate on request! Learn more at tsubaki-kabelschlepp.com/totaltrax



TRAXLINE® cables for cable carriers

Hi-flex electric cables which were especially developed, optimized and tested for use in cable carriers can be found at traxline.de

LC60 RSH | Inner distribution | TS3

Divider system TS3 with height separation consisting of plastic partitions

As a standard, the divider **version A** is used for vertical partitioning within the cable carrier. The complete divider system can be moved within the cross section.

Key for abbreviations on page 16

Design guidelines from page 64

Technical support: technik@kabelschlepp.de

Divider version A



End divider

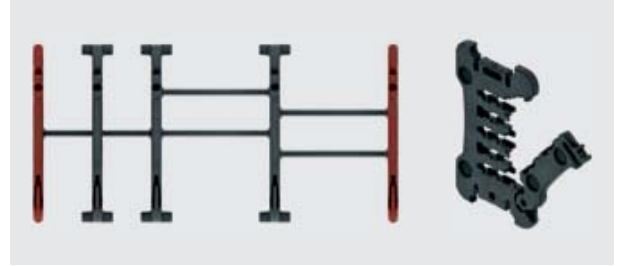

Vers.	a_T min [mm]	a_x min [mm]	a_c min [mm]	n_T min
A	8/4*	14	10	2

* For End divider

The dividers are fixed by the partitions, the complete divider system is movable in the cross section.

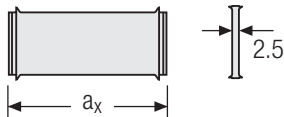
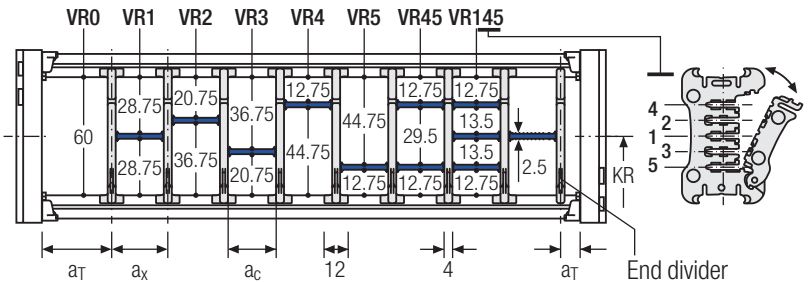

a_x (center distance of dividers) [mm]																
a_c (nominal width of inner chamber) [mm]																
14	16	19	23	24	28	29	32	33	34	38	39	43	44	48	49	54
10	12	15	19	20	24	25	28	29	30	34	35	39	40	44	45	50
58	59	64	68	69	74	78	79	80	84	88	89	94	96	99	112	
54	55	60	64	65	70	74	75	76	80	84	85	90	92	95	108	

An additional central support is required when using plastic partitions with $a_x > 49$ mm.

Order example

TS3 .
 A .
 3 .
 K1 .
 34 -
 VR1
 ⋮ ⋮ ⋮
K4 .
 38 -
 VR3
 Divider system Version n_T Chamber a_x Height separation

Please state the designation of the divider system (TS0, TS1,...), version and number of dividers per cross section [n_T]. In addition, please also enter the chambers [K] from left to right, as well as the assembly distances [a_T/a_x] (as seen from the driver).

If using divider systems with height separation (TS1, TS3) please also state the positions [e.g. VD23] viewed from the left driver belt. You are welcome to add a sketch to your order.

The next generation of the TS3 divider system

Width optimized for more space in the same cable carrier

Width comparison

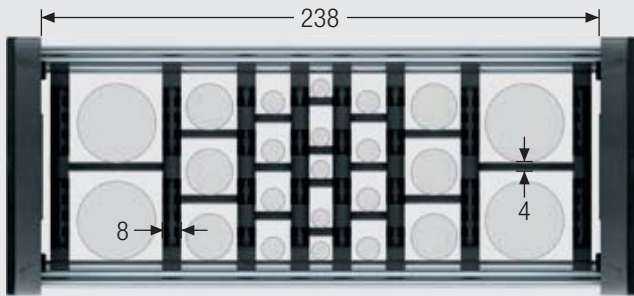

Previous divider system TS3 with stay variant RE

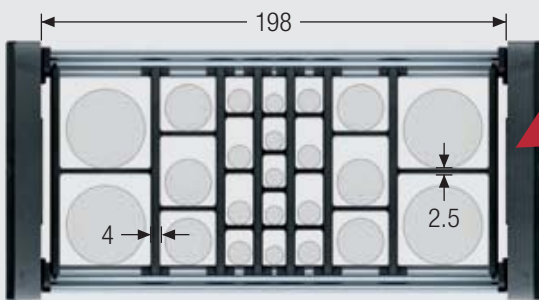

Significant space saving with same filling capacity through the new divider system TS3 with stay variant RE

Width optimization through adapted dividers

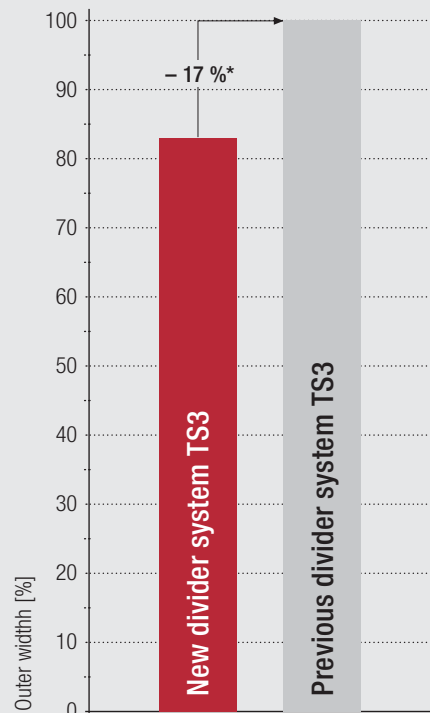

*For inner width $B_i = 238$ mm with stay variant RE

Inner heights



Inner widths



Increments



tsubaki-kabelschlepp.com/master

Easy-to-assemble cable separation on the smallest footprint



1
Insert cables, open dividers and insert first height separator

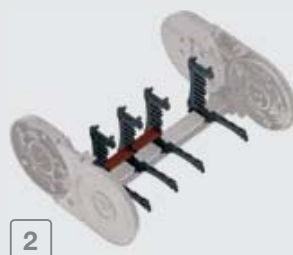

2
Insert additional cables, insert height separators



3
Insert cables, complete height separators



4
Close dividers

LE60 RE | Dimensions · Technical data

Plastic stay RE – frame screw-in stay

- Plastic profile bars for light to medium loads. Assembly without screws.
- **Outside/inside:** release by rotating.

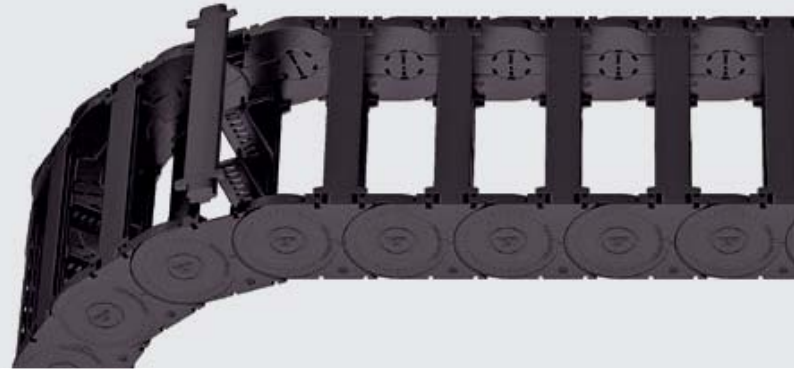

Key for abbreviations
on page 16



Stays mounted on each chain link (**VS: fully-stayed**)



B_i 85 – 250 mm

Design guidelines
from page 64

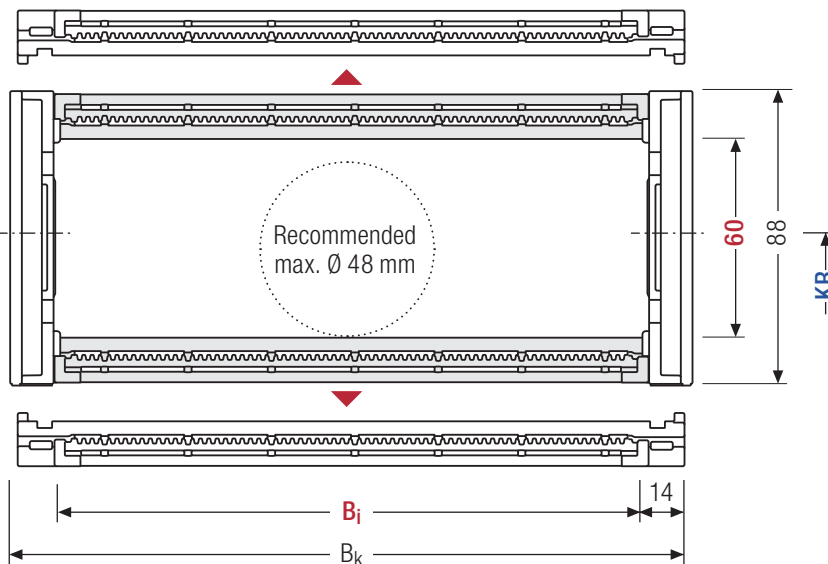

The maximum cable diameter strongly depends on the bending radius and the desired cable type. Please contact us.

Calculating the cable carrier length

Cable carrier length L_k

$$L_k \approx \frac{L_S}{2} + L_B$$

Cable carrier length L_k
rounded to pitch t

Technical support:
technik@kabelschlepp.de

h_i [mm]	h_G [mm]	B_i [mm]				B_k [mm]	KR [mm]					q_k [kg/m]
60	88	85	125	138	150	$B_i + 28$	135	150	175	200	250	3.00 – 4.20
		180	196	225	250		300	350	400	500		

Order example



LE 60 . **180** . **RE** . **250** - **2184**
Type B_i [mm] Stay variant KR [mm] L_k [mm]

VS
Stay arrangement

Divider systems

The divider system is mounted on every 2nd chain link as a standard.

As a standard, dividers or the complete divider system (dividers with height separations) are movable in the cross section (**version A**).

Inner heights

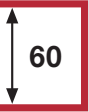

Divider system TS0 without height separation

Vers.	a_T min [mm]	a_x min [mm]	a_c min [mm]	n_T min
A	10	13	9	—

The dividers can be moved within the cross section.

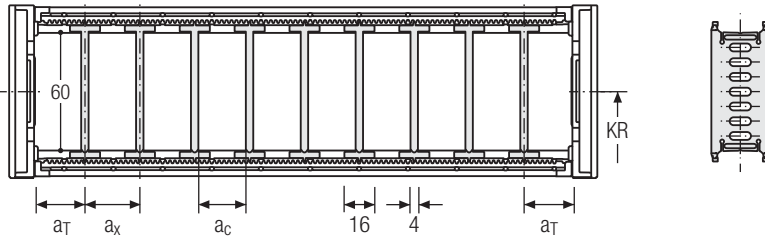

Inner widths



Divider system TS1 with continuous height separation

Vers.	a_T min [mm]	a_x min [mm]	a_c min [mm]	n_T min
A	10	13	9	2

The dividers can be moved within the cross section.

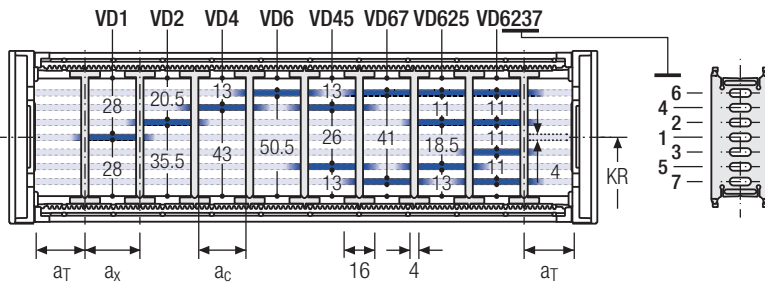

tsubaki-kabelschlepp.com/
master



TOTALTRAX® complete systems

Benefit from the advantages of the TOTALTRAX® complete system. A complete delivery from one source – with a warranty certificate on request! Learn more at tsubaki-kabelschlepp.com/totaltrax



TRAXLINE® cables for cable carriers

Hi-flex electric cables which were especially developed, optimized and tested for use in cable carriers can be found at traxline.de

LE60 RE | Inner distribution | TS3

Divider system TS3 with height separation consisting of plastic partitions

As a standard, the divider **version A** is used for vertical partitioning within the cable carrier. The complete divider system can be moved within the cross section.

Key for abbreviations
on page 16

Design guidelines
from page 64

Technical support:
technik@kabelschlepp.de

Divider version A

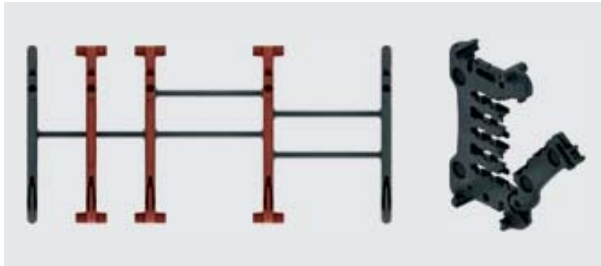

End divider

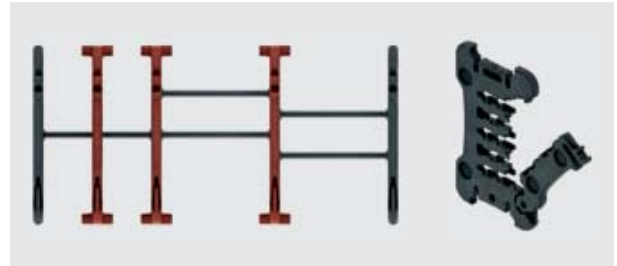

Vers.	a _T min [mm]	a _x min [mm]	a _c min [mm]	n _T min
A	8/4*	14	10	2

* For End divider

The dividers are fixed by the partitions, the complete divider system is movable in the cross section.

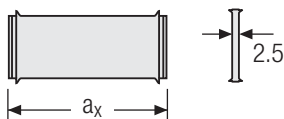
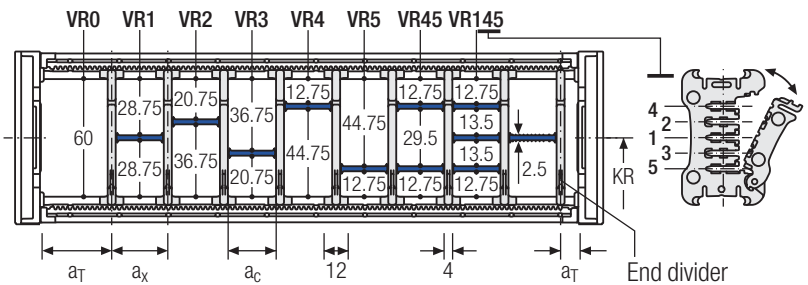

a _x (center distance of dividers) [mm]																
a _c (nominal width of inner chamber) [mm]																
14	16	19	23	24	28	29	32	33	34	38	39	43	44	48	49	54
10	12	15	19	20	24	25	28	29	30	34	35	39	40	44	45	50
58	59	64	68	69	74	78	79	80	84	88	89	94	96	99	112	
54	55	60	64	65	70	74	75	76	80	84	85	90	92	95	108	

An additional central support is required when using plastic partitions with a_x > 49 mm.

Order example

TS3 . A . 3 . K1 . 34 - VR1
 ⋮ ⋮ ⋮
K4 . 38 - VR3

Divider system
Version
n_T
Chamber
a_x
Height separation

Please state the designation of the divider system (TS0, TS1,...), version and number of dividers per cross section [n_T]. In addition, please also enter the chambers [K] from left to right, as well as the assembly distances [a_T/a_x] (as seen from the driver).

If using divider systems with height separation (TS1, TS3) please also state the positions [e.g. VD23] viewed from the left driver belt. You are welcome to add a sketch to your order.

L60 | End connectors | Plastic

Universal end connectors UMB – plastic (standard)

The universal mounting brackets (UMB) are made from plastic and can be mounted **from the top, from the bottom or face on**.

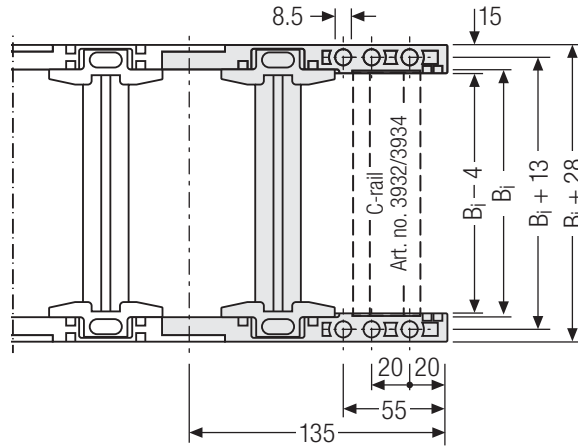
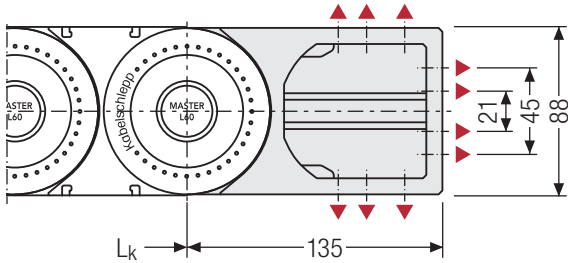

▲ Assembly options

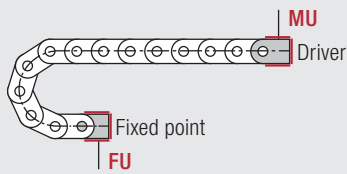

Connection point

- F** – fixed point
- M** – driver

Connection type

- U** – universal mounting bracket

Order example

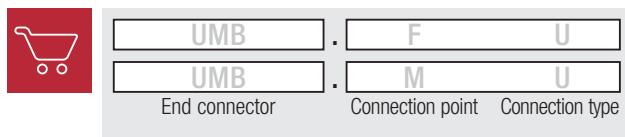

 We recommend the use of strain reliefs before driver and fixed point. See from p. 834.

More product information online



Assembly instructions etc.:
Additional info via your smartphone or check online at tsubaki-kabelschlepp.com/support



Configure your cable carrier here:
onlineengineer.de



L80

Key for abbreviations
on page 16



Pitch
111 mm

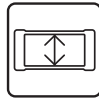

Inner height
80 mm

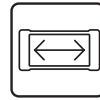

Inner widths
85 – 800 mm

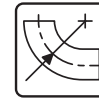

Bending radii
150 – 500 mm

Design guidelines
from page 64

Stay variants

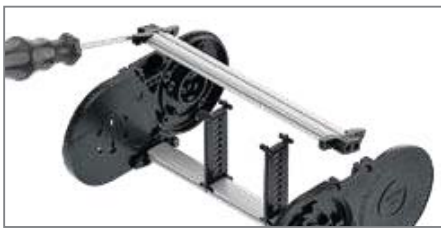

Aluminum stay RSH page 332

Frame screw-in stay

- Aluminum profile bars for light to medium loads. Assembly without screws.
- **Outside/inside:** release by rotating 90°.



Plastic stay RE page 336

Frame screw-in stay

- Plastic profile bars for light to medium loads. Assembly without screws.
- **Outside/inside:** release by rotating 90°.

Technical support:
technik@kabelschlepp.de



TOTALTRAX® complete systems

Benefit from the advantages of the TOTALTRAX® complete system. A complete delivery from one source – with a warranty certificate on request! Learn more at tsubaki-kabelschlepp.com/totaltrax



TRAXLINE® cables for cable carriers

Hi-flex electric cables which were especially developed, optimized and tested for use in cable carriers can be found at traxline.de

L80 | Installation dim. | Unsupported

Unsupported arrangement

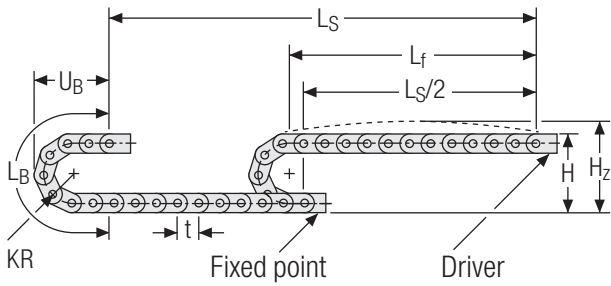

KR [mm]	H [mm]	H _z [mm]	L _B [mm]	U _B [mm]
150	410	470	694	316
200	510	570	851	366
250	610	670	1008	416
300	710	770	1165	466
350	810	870	1322	516
400	910	970	1479	566
500	1110	1170	1793	666

Inner heights

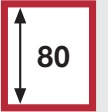

Inner widths



Load diagram for unsupported length depending on the additional load.

Sagging of the cable carrier is technically permitted for extended travel lengths, depending on the specific application.

Intrinsic cable carrier weight $q_k = 5.63 \text{ kg/m}$. For other inner widths, the maximum additional load changes.

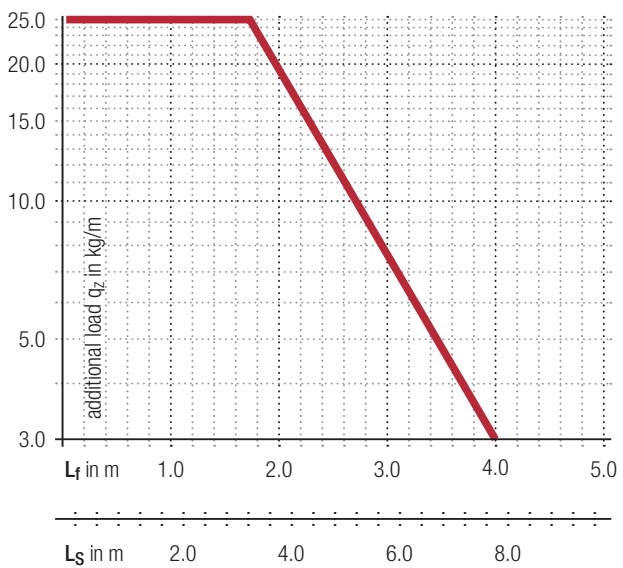

 **Speed**
up to 5 m/s

 **Acceleration**
up to 25 m/s²

 **Travel length**
up to 7.9 m

 **Additional load**
up to 25 kg/m

More product information online



Assembly instructions etc.:
Additional info via your
smartphone or check online at
[tsubaki-kabelschlepp.com/
support](http://tsubaki-kabelschlepp.com/support)



Configure your cable carrier here:
online-engineer.de

LC80 RSH | Dimensions · Technical data

Plastic stay RSH – screw-in frame stay

- Aluminum profile bars for light to medium loads. Assembly without screws.
- Available customized in **1 mm grid**.
- **Outside/inside:** release by rotating.

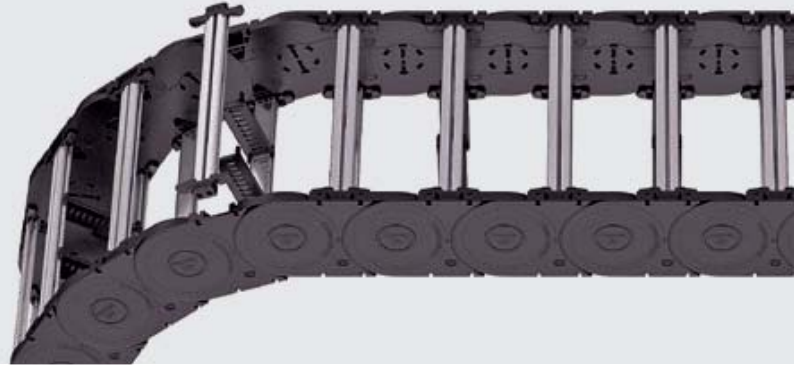

Key for abbreviations on page 16



Stays mounted on each chain link (**VS: fully-stayed**)



1 mm B_i 100 – 800 mm in **1 mm width sections**

Design guidelines from page 64

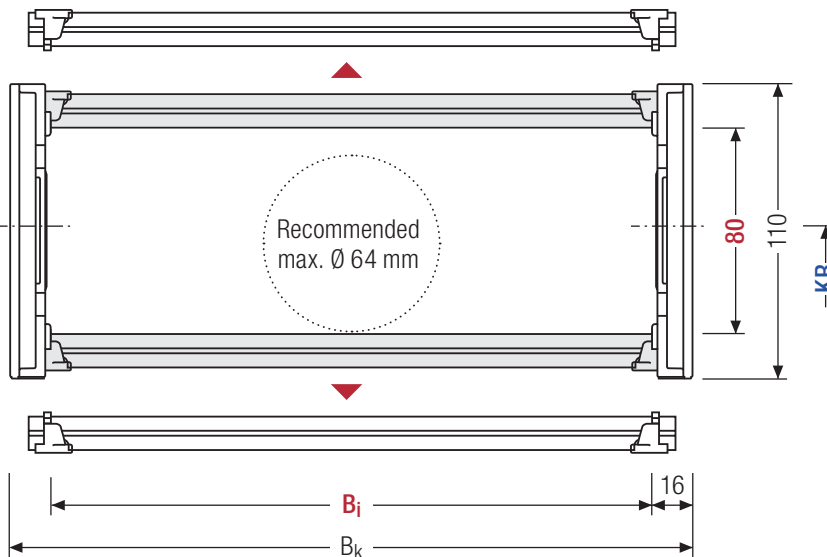

The maximum cable diameter strongly depends on the bending radius and the desired cable type. Please contact us.

Calculating the cable carrier length

Cable carrier length L_k

$$L_k \approx \frac{L_S}{2} + L_B$$

Cable carrier length L_k rounded to pitch t

Technical support: technik@kabelschlepp.de

h _i [mm]	h _G [mm]	B _i [mm]*	B _k [mm]	KR [mm]						q _k [kg/m]	
80	110	100 – 800	B _i + 32	150	200	250	300	350	400	500	3.89 – 10.01

* in 1 mm width sections

Order example

LC 80
Type
500
B_i [mm]
RSH
Stay variant
300
KR [mm]
2442
L_k [mm]
VS
Stay arrangement

Divider systems

The divider system is mounted on every 2nd chain link as a standard.

As a standard, dividers or the complete divider system (dividers with height separations) are movable in the cross section (**version A**).

For applications with lateral acceleration and lying on the side, the dividers can be attached by a fixing profile, available as an accessory (**version B**). The fixing profile must be installed at the factory.

Inner heights

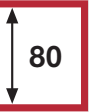

Inner widths



Increments



Divider system TSO without height separation

Vers.	a_T min [mm]	a_x min [mm]	a_c min [mm]	a_x grid [mm]	n_T min
A	10	16	12	—	—
B	10	16	12	3	—

The dividers can be moved within the cross section (version A) or fixed (version B).

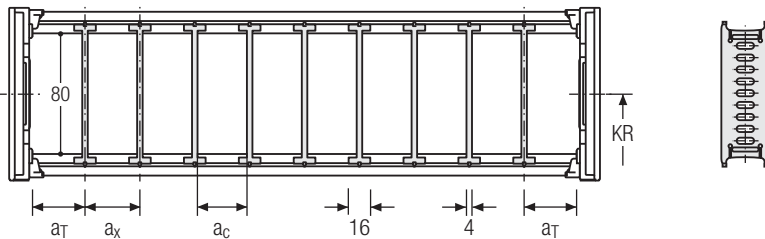

Divider system TS1 with continuous height separation

Vers.	a_T min [mm]	a_x min [mm]	a_c min [mm]	a_x grid [mm]	n_T min
A	10	16	12	—	2
B	10	16	12	3	2

The dividers can be moved within the cross section (version A) or fixed (version B).

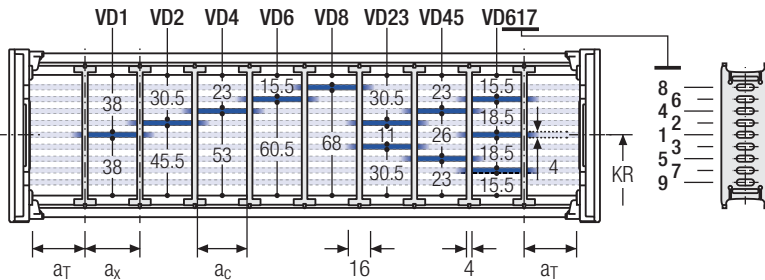

tsubaki-kabelschlepp.com/
master



TOTALTRAX® complete systems

Benefit from the advantages of the TOTALTRAX® complete system. A complete delivery from one source – with a warranty certificate on request! Learn more at tsubaki-kabelschlepp.com/totaltrax



TRAXLINE® cables for cable carriers

Hi-flex electric cables which were especially developed, optimized and tested for use in cable carriers can be found at traxline.de

LC80 RSH | Inner distribution | TS3

Divider system TS3 with height separation consisting of plastic partitions

As a standard, the divider **version A** is used for vertical partitioning within the cable carrier. The complete divider system can be moved within the cross section.

Key for abbreviations
on page 16

Design guidelines
from page 64

Technical support:
technik@kabelschlepp.de

Divider version A

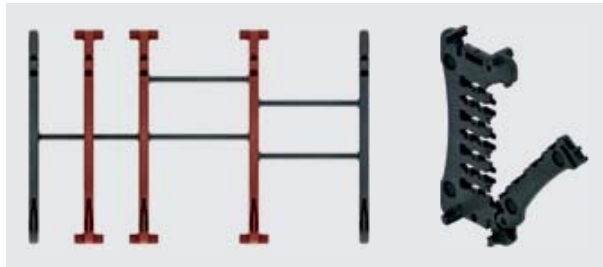

End divider

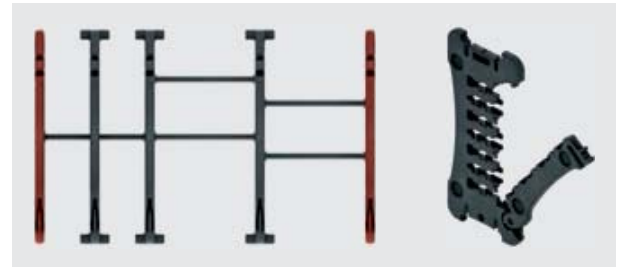

Vers.	a_T min [mm]	a_x min [mm]	a_c min [mm]	n_T min
A	8/4*	14	10	2

* For End divider

The dividers are fixed by the partitions, the complete divider system is movable in the cross section.

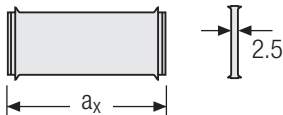
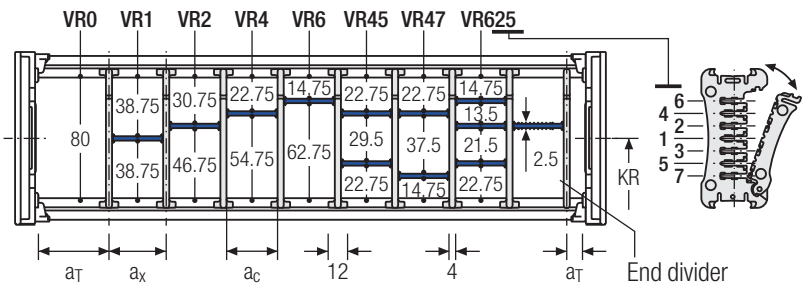

a_x (center distance of dividers) [mm]																
a_c (nominal width of inner chamber) [mm]																
14	16	19	23	24	28	29	32	33	34	38	39	43	44	48	49	54
10	12	15	19	20	24	25	28	29	30	34	35	39	40	44	45	50
58	59	64	68	69	74	78	79	80	84	88	89	94	96	99	112	
54	55	60	64	65	70	74	75	76	80	84	85	90	92	95	108	

An additional central support is required when using plastic partitions with $a_x > 49$ mm.

Order example

	TS3	.	A	.	3	.	K1	.	34	.	VR1
							⋮		⋮		⋮
							K4	.	38	.	VR3
	Divider system		Version		n_T		Chamber		a_x		Height separation

Please state the designation of the divider system (TS0, TS1,...), version and number of dividers per cross section [n_T]. In addition, please also enter the chambers [K] from left to right, as well as the assembly distances [a_T/a_x] (as seen from the driver).

If using divider systems with height separation (TS1, TS3) please also state the positions [e.g. VD23] viewed from the left driver belt. You are welcome to add a sketch to your order.

The next generation of the TS3 divider system

Width optimized for more space in the same cable carrier

Width comparison

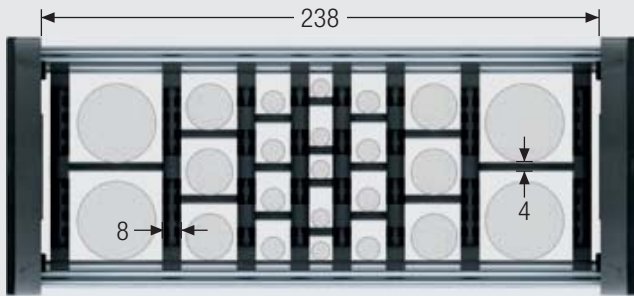

Previous divider system TS3 with stay variant RE

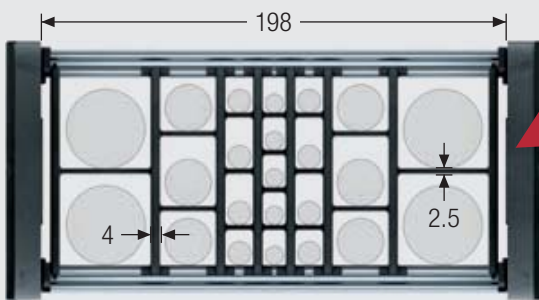

Significant space saving with same filling capacity through the new divider system TS3 with stay variant RE

Width optimization through adapted dividers

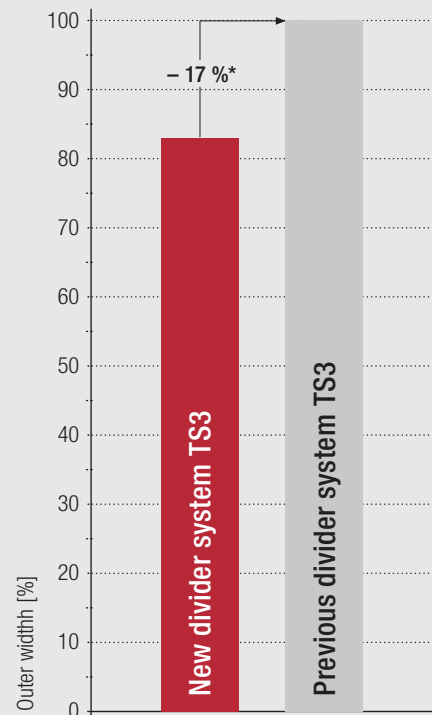

*For inner width $B_i = 238$ mm with stay variant RE

Inner heights



Inner widths



Increments



tsubaki-kabelschlepp.com/master

Easy-to-assemble cable separation on the smallest footprint



1
Insert cables, open dividers and insert first height separator



2
Insert additional cables, insert height separators



3
Insert cables, complete height separators



4
Close dividers

LE80 RE | Dimensions · Technical data

Plastic stay RE – frame screw-in stay

- Plastic profile bars for light to medium loads. Assembly without screws.
- **Outside/inside:** release by rotating.

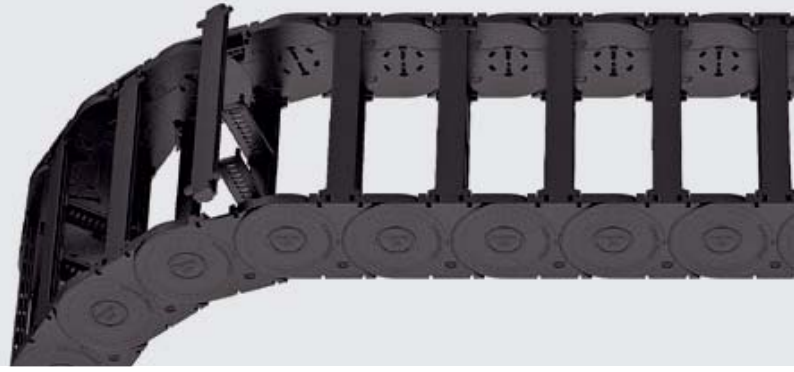

Key for abbreviations
on page 16



Stays mounted on each chain link (**VS: fully-stayed**)



B_i 85 – 250 mm

Design guidelines
from page 64

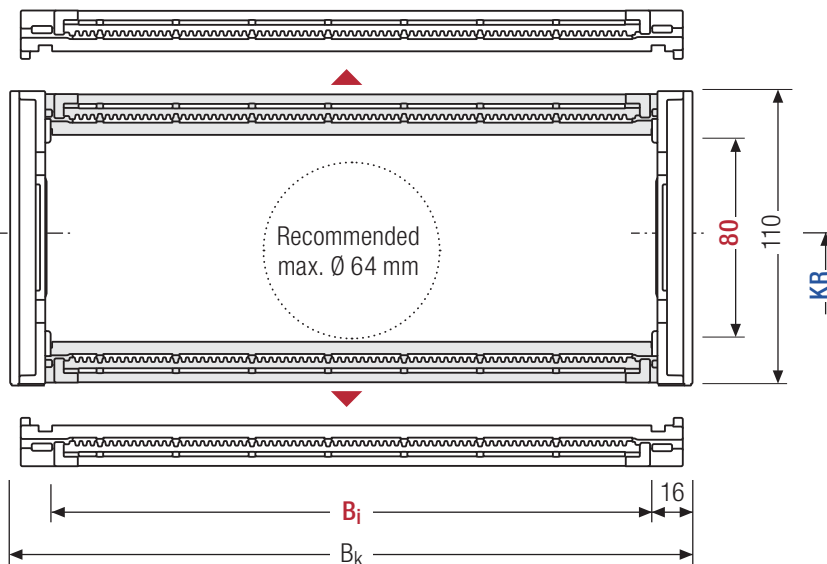

The maximum cable diameter strongly depends on the bending radius and the desired cable type. Please contact us.

Calculating the cable carrier length

Cable carrier length L_k

$$L_k \approx \frac{L_s}{2} + L_B$$

Cable carrier length L_k
rounded to pitch t

Technical support:
technik@kabelschlepp.de

h_i [mm]	h_G [mm]	B_i [mm]				B_k [mm]	KR [mm]			q_k [kg/m]
80	110	85	125	138	150	$B_i + 32$	150	200	300	3.84 – 4.83
		180	196	225	250		350	400	500	

Order example

LE 80
Type
·
250
· B_i [mm]
·
RE
· Stay variant
·
300
· KR [mm]
·
2442
· L_k [mm]
·
VS
· Stay arrangement

Divider systems

The divider system is mounted on every 2nd chain link as a standard.

As a standard, dividers or the complete divider system (dividers with height separations) are movable in the cross section (**version A**).

For applications with lateral acceleration and lying on the side, divider with arresting cams are available. These can be fixed in the latching profile of the stays (**version B**).

Inner heights

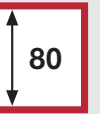

Inner widths



Divider system TS0 without height separation

Vers.	a _T min [mm]	a _x min [mm]	a _c min [mm]	a _x grid [mm]	n _T min
A	10	16	12	—	—
B	10	16	12	2.5	—

The dividers can be moved within the cross section (version A) or fixed (version B).

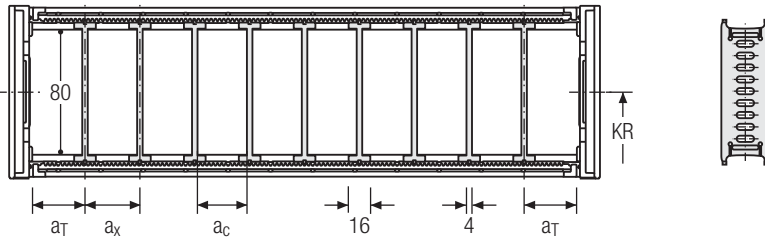

Divider system TS1 with continuous height separation

Vers.	a _T min [mm]	a _x min [mm]	a _c min [mm]	a _x grid [mm]	n _T min
A	10	16	12	—	2
B	10	16	12	2.5	2

The dividers can be moved within the cross section (version A) or fixed (version B).

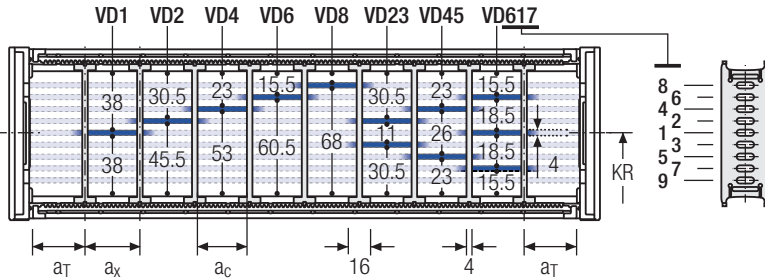

TOTALTRAX® complete systems

Benefit from the advantages of the TOTALTRAX® complete system. A complete delivery from one source – with a warranty certificate on request! Learn more at tsubaki-kabelschlepp.com/totaltrax



TRAXLINE® cables for cable carriers

Hi-flex electric cables which were especially developed, optimized and tested for use in cable carriers can be found at traxline.de

LE80 RE | Inner distribution | TS3

Divider system TS3 with height separation consisting of plastic partitions

As a standard, the divider **version A** is used for vertical partitioning within the cable carrier. The complete divider system can be moved within the cross section.

Key for abbreviations
on page 16

Design guidelines
from page 64

Technical support:
technik@kabelschlepp.de

Divider version A

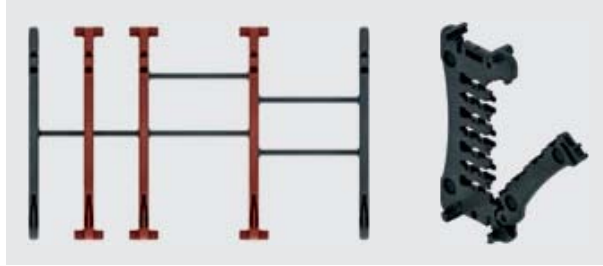

End divider

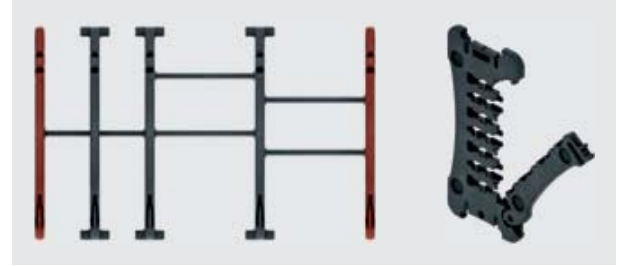

Vers.	a _T min [mm]	a _x min [mm]	a _c min [mm]	n _T min
A	8/4*	14	10	2

* For End divider

The dividers are fixed by the partitions, the complete divider system is movable in the cross section.

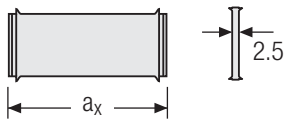
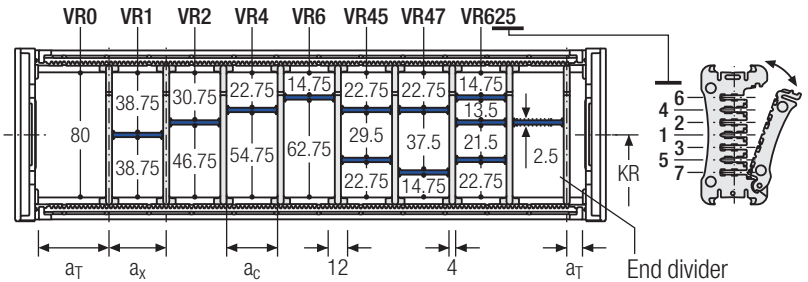

a _x (center distance of dividers) [mm]																
a _c (nominal width of inner chamber) [mm]																
14	16	19	23	24	28	29	32	33	34	38	39	43	44	48	49	54
10	12	15	19	20	24	25	28	29	30	34	35	39	40	44	45	50
58	59	64	68	69	74	78	79	80	84	88	89	94	96	99	112	
54	55	60	64	65	70	74	75	76	80	84	85	90	92	95	108	

An additional central support is required when using plastic partitions with a_x > 49 mm.

Order example

TS3 .
 A .
 3 .
 K1 .
 34 -
 VR1
 ⋮ ⋮ ⋮
K4 .
 38 -
 VR3

Divider system Version n_T Chamber a_x Height separation

Please state the designation of the divider system (TS0, TS1,...), version and number of dividers per cross section [n_T]. In addition, please also enter the chambers [K] from left to right, as well as the assembly distances [a_T/a_x] (as seen from the driver).

If using divider systems with height separation (TS1, TS3) please also state the positions [e.g. VD23] viewed from the left driver belt. You are welcome to add a sketch to your order.

L80 | End connectors | Plastic

Universal end connectors UMB – plastic (standard)

The universal mounting brackets (UMB) are made from plastic and can be mounted **from the top, from the bottom or face on**.

Short version, closed

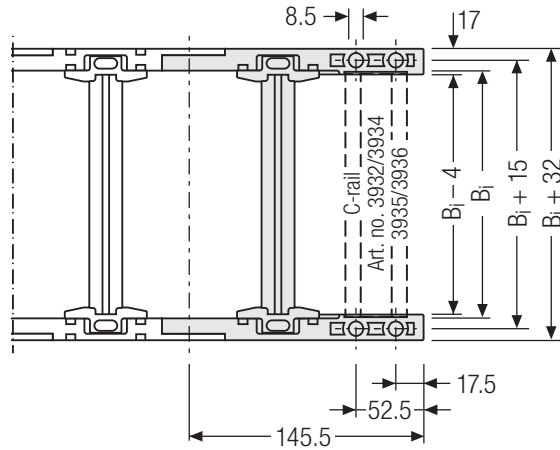
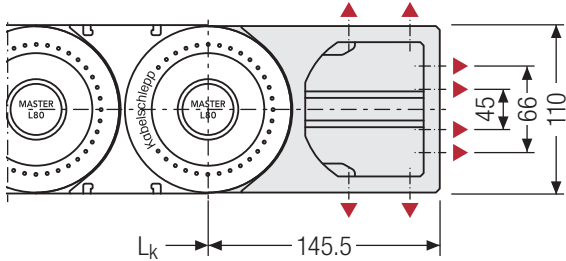

Long version, closed

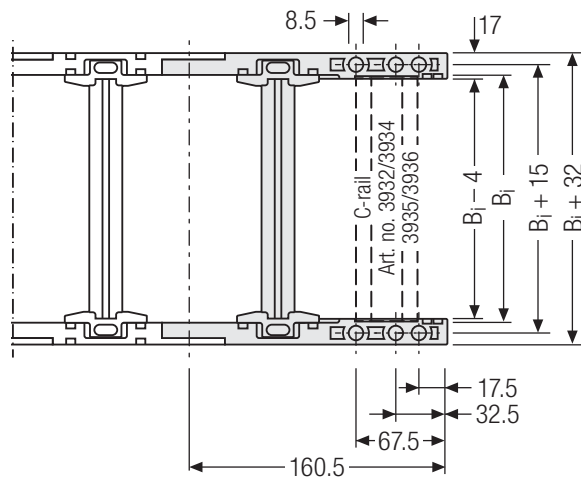
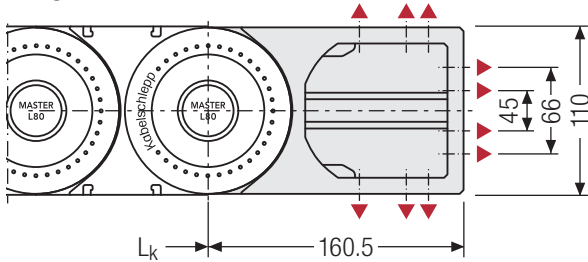

Inner heights

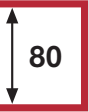

Inner widths



tsubaki-kabelschlepp.com/
master



Optionally, the end connectors are available in an **open** version for easy mounting. Please state when ordering.

▲ Assembly options

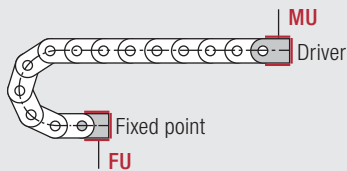

Connection point

F – fixed point
M – driver

Connection type

U – universal mounting bracket

Order example

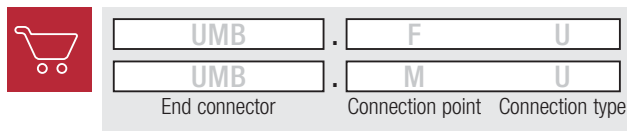

i We recommend the use of strain reliefs before driver and fixed point. See from p. 834.