

# QuickTrax<sup>®</sup> series

Compact and cost-effective  
cable carriers in  
two-component technology



Trademarks are legally protected for the TSUBAKI KABELSCHLEPP GmbH  
as a national or international registration in the following countries:  
[tsubaki-kabelschlepp.com/trademarks](http://tsubaki-kabelschlepp.com/trademarks)

Subject to change without notice.

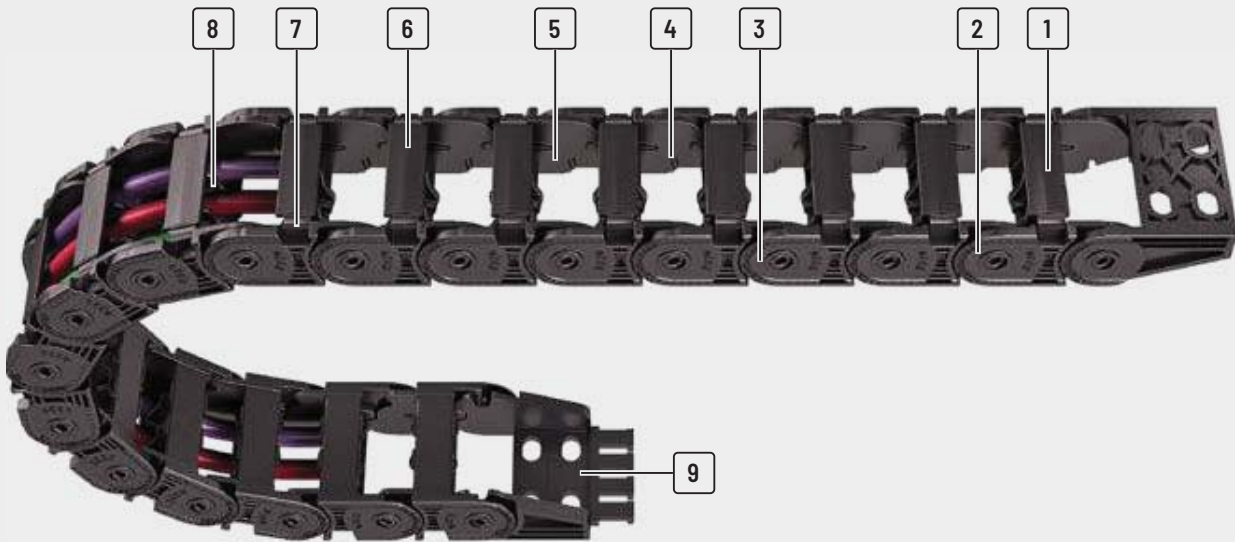

- 1 Sturdy 2-component design: hard chain body, flexible film hinge
- 2 Plastic chain links
- 3 Extensive unsupported length
- 4 Inside space is gentle on the cables – no interfering edges
- 5 Very quiet through integrated noise damping
- 6 Quick and easy to open
- 7 Inside/outside openable
- 8 Dividers and height separations for cable separation
- 9 Single-part end connectors with and without integratable strain relief

## Features

- » Extremely fast and easy cable laying thanks to crossbar with film hinge
- » Each chain link consists of two different materials:
  - Hard chain body made of glass-fibre reinforced material
  - Crossbar with flexible film hinge made of elastic special plastic

- » Sturdy cable carrier design
- » High torsional rigidity
- » Very quiet through integrated noise damping
- » Extensive unsupported length



Easy to open...



...even without tools



High side stability



Reliable cable separation

## Cable carrier design

Solid plastic cable carriers: chain links and end connectors made of plastic

Each chain link consists of two different materials:

- » Hard cable carrier body made of glass fiber-reinforced material
- » Flexible lamellae made of elastic plastic



## The two-component technology of the QuickTrax®

The two-component technology of the **QuickTrax®** combines two seemingly incompatible features: **Stability and flexibility.**

Cable carriers need to be extremely sturdy, with extensive unsupported length. At the same time, cables need to be inserted easily for fast cable laying.

The **QuickTrax®** meets these requirements thanks to its innovative design and material combination of a hard cable carrier body made from glass fiber-reinforced material and crossbars with a film hinge made from rigid special plastic.

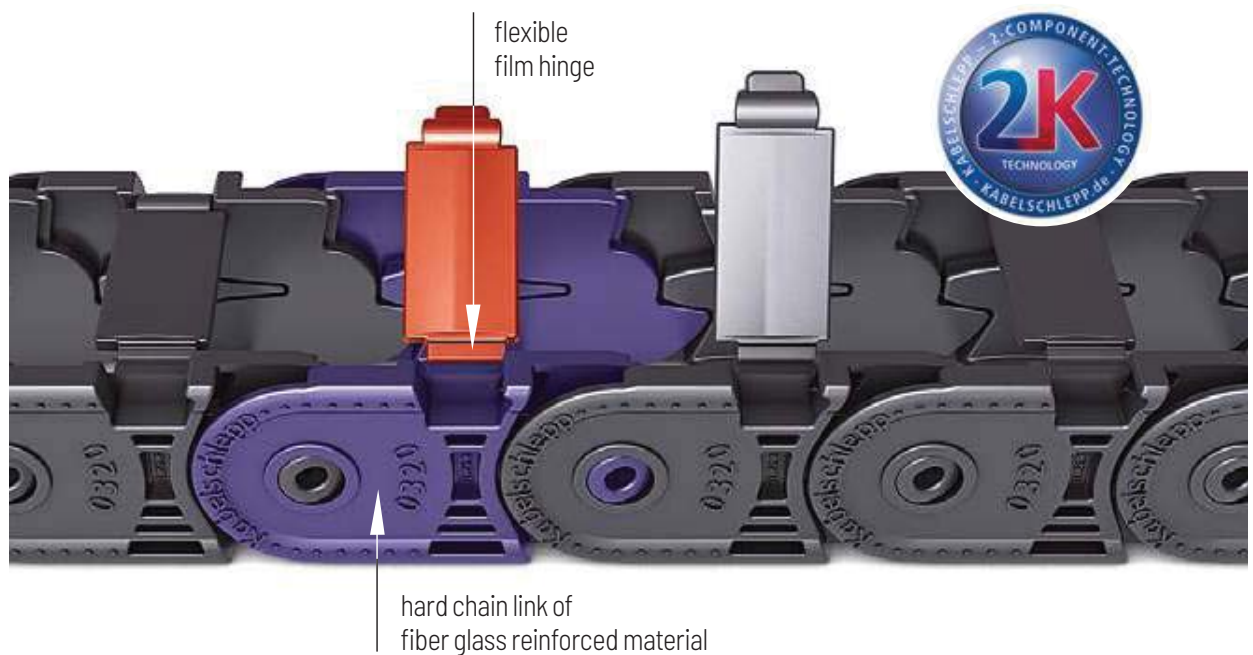
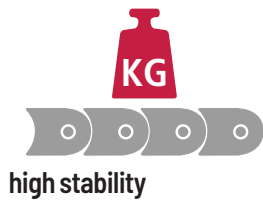
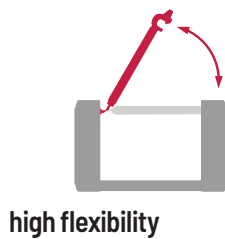

hard chain link of fiber glass reinforced material

Cable carrier

Cable carrier configuration

Configuration guidelines

Materials information

MONO series

**QuickTrax® series**

UNIFLEX Advanced series

TKP35 series

TKK series

EasyTrax® series

## Comparison of dimensions

Manufacturer	$h_i$ [mm]	$h_G$ [mm]	$t$ [mm]	Identical connection hole pattern
QuickTrax®	20.0	25.5	32.0	yes
Competitive product	17.5	23.0	30.5	yes

## Comparison of bending moment

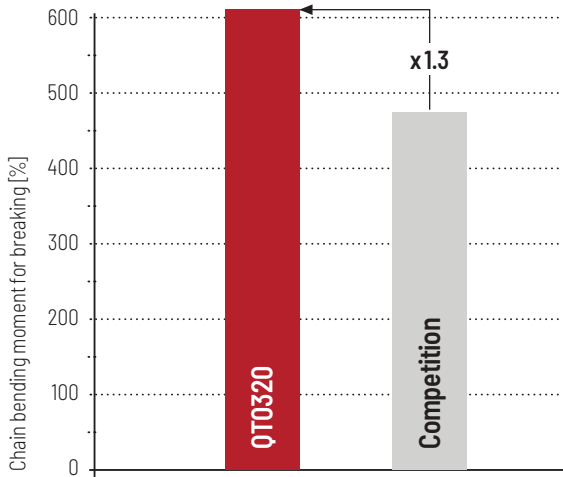

## Comparison of bending strength

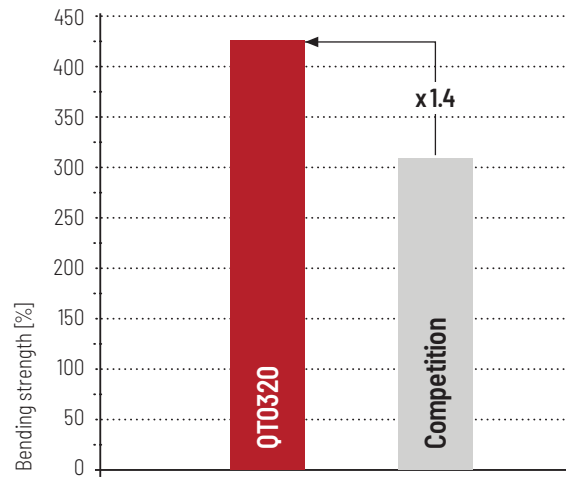

## Load diagram

for unsupported length depending on additional load

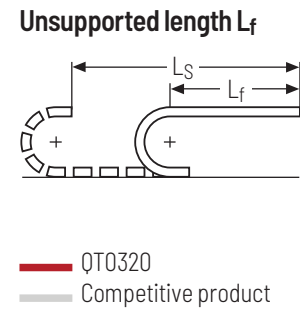
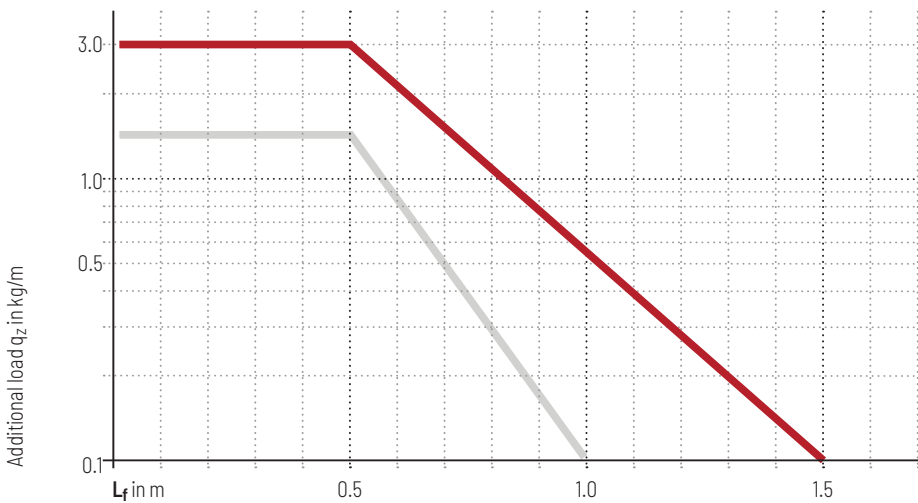

## Advantages over competitive product

- » 20 % longer unsupported length compared to competitive product
- » 33 % greater additional load through use of fiber glass reinforced plastic
- » Greater inner height
- » Low noise operation due to internal damping system
- » High side stability through locking in the stroke system
- » Dividers can be used for cable separation

# QuickTrax® series | Overview

	Cable carrier	Cable carrier configuration	Configuration guidelines	Materials information	MONO series	QuickTrax® series	UNIFLEX Advanced series	TKP35 series	TKK series	EasyTrax® series	
Type	Opening variant	Stay variant	$h_i$ [mm]	$h_G$ [mm]	$B_i$ [mm]	$B_k$ [mm]	$B_i$ -grid [mm]	t [mm]	KR [mm]	Additional load $\leq$ [kg/m]	Cable- $d_{max}$ [mm]
<b>QT0250</b>											
		030	17.6	23	30 - 50	60	-	25	28 - 100	4	14
		040	17.6	23	30 - 50	60	-	25	28 - 100	4	14
<b>QT0320</b>											
		030	20	25,5	15 - 65	27 - 77	-	32	28 - 125	3	16
		040	20	25,5	15 - 65	27 - 77	-	32	28 - 125	3	16

# QuickTrax® series | Overview

Unsupported arrangement			Gliding arrangement			Inner Distribution				Movement			Page
Travel length ≤ [m]	$v_{max} \leq [m/s]$	$a_{max} \leq [m/s^2]$	Travel length ≤ [m]	$v_{max} \leq [m/s]$	$a_{max} \leq [m/s^2]$	TS0	TS1	TS2	TS3	vertical hanging or standing	lying on the side	rotating arrangement	
1.6	10	50	60	3	30	•	•	-	-	•	•	•	134
1.6	10	50	-	-	-	•	•	-	-	•	•	•	135
2.9	10	50	80	2.5	25	•	•	-	-	•	•	•	140
2.9	10	50	-	-	-	•	•	-	-	•	•	•	141

Cable carrier

Cable carrier configuration

Configuration guidelines

Materials information

MONO series

QuickTrax® series

UNIFLEX Advanced series

TKP35 series

TKK series

EasyTrax® series

# QT0250

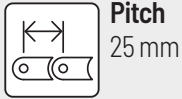

**Pitch**  
25 mm



**Inner height**  
17,6 mm

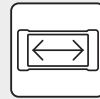

**Inner widths**  
30 - 50 mm



**Bending radii**  
28 - 100 mm

## Stay variants



**Design 030** ..... page **134**

### Frame with outside opening crossbars

- » Weight-optimised plastic frame with particularly high torsional rigidity.
- » Crossbar can be opened at any position on one side.
- » **Outside:** openable.



**Design 040** ..... page **135**

### Frame with inside opening crossbars

- » Weight-optimised plastic frame with particularly high torsional rigidity.
- » Crossbar can be opened at any position on one side.
- » **Inside:** openable.

Cable carrier

Cable carrier configuration

Configuration guidelines

Materials information

MONO series

QuickTrax® series

UNIFLEX Advanced series

TKP35 series

TKK series

EasyTrax® series



### UNIFLEX Advanced

For a non-opening cable carrier with 17.5 mm inner height we recommend the series UNIFLEX Advanced UA1250 from page 150.

### Unsupported arrangement

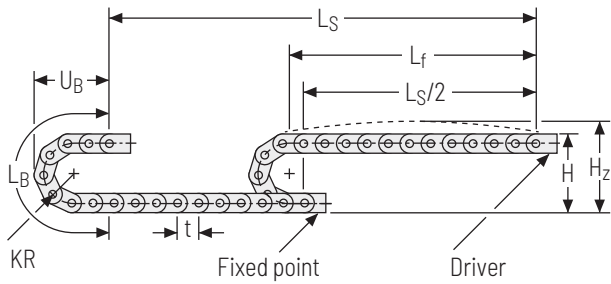

KR [mm]	H [mm]	H <sub>z</sub> [mm]	L <sub>B</sub> [mm]	U <sub>B</sub> [mm]
28	79	104	138	65
38	99	124	169	75
45	113	138	191	82
60	143	168	238	97
75	173	198	286	112
100	223	248	364	137

### Load diagram for unsupported length

depending on the additional load.

Intrinsic cable carrier weight  $q_k = 0.36 \text{ kg/m}$  with  $B_i = 50 \text{ mm}$ . For other inner widths, the maximum additional load changes.

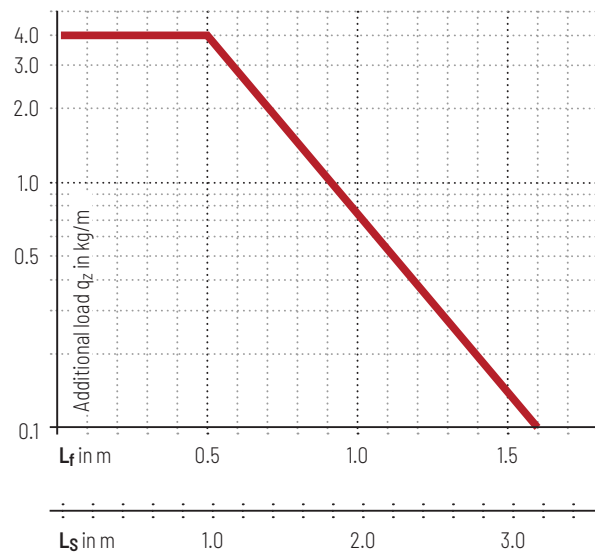

**Speed**  
up to 10 m/s



**Acceleration**  
up to 50 m/s<sup>2</sup>



**Travel length**  
up to 1.6 m



**Additional load**  
up to 4 kg/m

### Gliding arrangement

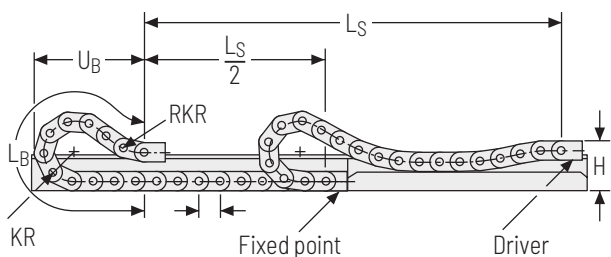

**Speed**  
up to 3 m/s



**Acceleration**  
up to 30 m/s<sup>2</sup>



**Travel length**  
up to 60 m



**Additional load**  
up to 4 kg/m



The gliding cable carrier must be guided in a channel. See p. 850.

Only design 030 can be used for a gliding arrangement.

Cable carrier
Cable carrier configuration
Configuration guidelines
Materials information
MONO series
<b>QuickTrax® series</b>
UNIFLEX Advanced series
TKP35 series
TKK series
EasyTrax® series



### Stay variant 030 – with outside opening crossbars

- » Weight-optimised plastic frame with particularly high torsional rigidity.
- » Crossbars can be opened at any position on one side
- » **Outside:** openable.



Stay arrangement on each chain link (**VS: fully-stayed**)



$B_i$  30 – 50 mm

Cable carrier

Cable carrier configuration

Configuration guidelines

Materials information

MONO series

QuickTrax® series

UNIFLEX Advanced series

TKP35 series

TKK series

EasyTrax® series

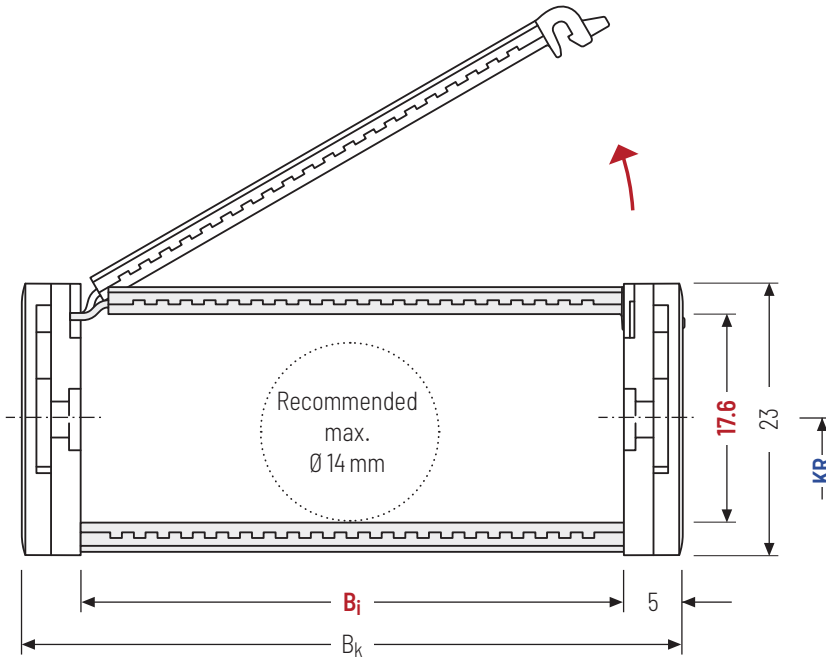

The maximum cable diameter strongly depends on the bending radius and the desired cable type. Please contact us.

#### Calculating the cable carrier length

##### Cable carrier length $L_k$

$$L_k \approx \frac{L_S}{2} + L_B$$

Cable carrier length  $L_k$  rounded to pitch  $t$

$h_i$ [mm]	$h_G$ [mm]	$B_i$ [mm]	$B_k$ [mm]	KR [mm]					$q_k$ [kg/m]		
17.6	23	30*	50	$B_i + 10$	28	38	45	60	75	100	0.32 – 0.36

\* on request

#### Order example

QT0250
030
50
75
1.100
VS

Type · Stay variant ·  $B_i$  [mm] · KR [mm] ·  $L_k$  [mm] · Stay arrangement

## Stay variant 040 - with inside opening crossbars

- » Weight-optimised plastic frame with particularly high torsional rigidity.
- » Crossbars can be opened at any position on one side
- » **Inside:** openable.



Stay arrangement on each chain link (VS: fully-stayed)



$B_i$  30 - 50 mm

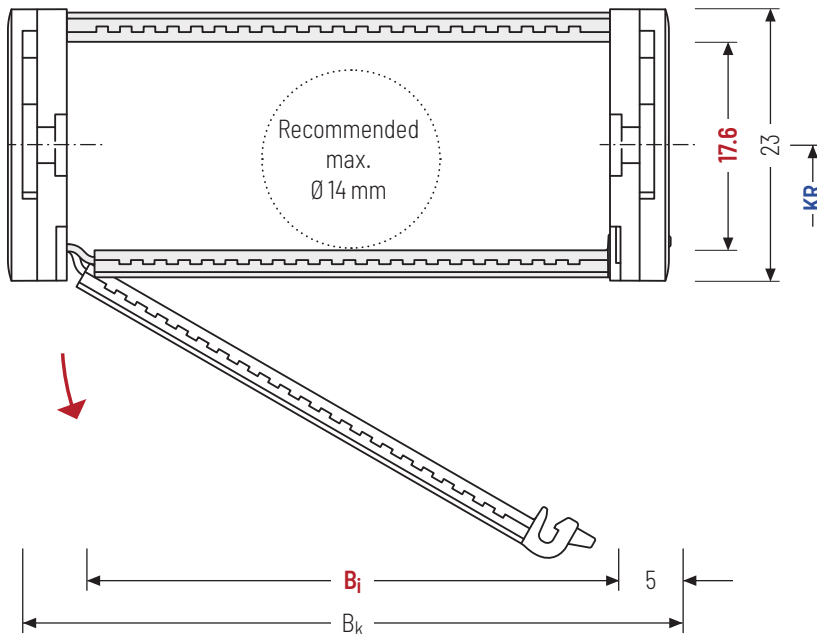

The maximum cable diameter strongly depends on the bending radius and the desired cable type. Please contact us.

### Calculating the cable carrier length

#### Cable carrier length $L_k$

$$L_k \approx \frac{L_S}{2} + L_B$$

Cable carrier length  $L_k$  rounded to pitch  $t$

$h_i$ [mm]	$h_G$ [mm]	$B_i$ [mm]	$B_k$ [mm]	KR [mm]					$q_k$ [kg/m]		
17.6	23	30*	50	$B_i + 10$	28	38	45	60	75	100	0.32 - 0.36

\* on request

### Order example



QT0250 Type	040 Stay variant	50 $B_i$ [mm]	75 KR [mm]	1.100 $L_k$ [mm]	VS Stay arrangement
----------------	---------------------	------------------	---------------	---------------------	------------------------

### Divider systems

The divider system is mounted on every 2<sup>nd</sup> chain link as a standard.

For applications with lateral accelerations and applications with the cable carrier rotated by 90°, the dividers can easily be fixed on the stay through rotation.

As a standard, dividers or the complete divider system (dividers with height separations) are movable in the cross section (**version A**).

The arresting cams snap into the catch profiles in the covers (**version B**).

### Divider system TSO without height separation

Vers.	a <sub>T</sub> min [mm]	a <sub>x</sub> min [mm]	a <sub>c</sub> min [mm]	a <sub>x</sub> grid [mm]	n <sub>T</sub> min
A	3	6	4	-	-
B	3	6	4	2	-

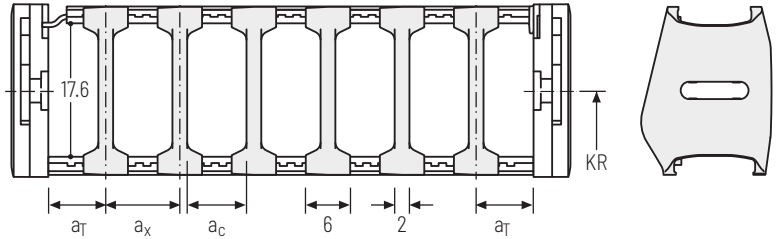

### Divider system TS1 with continuous height separation

Vers.	a <sub>T</sub> min [mm]	a <sub>x</sub> min [mm]	a <sub>c</sub> min [mm]	a <sub>x</sub> grid [mm]	n <sub>T</sub> min
A	3	6	4	-	2
B	3	6	4	2	2

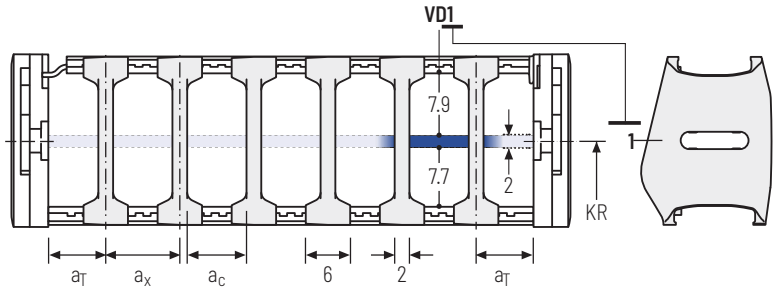

### Order example

TS1 . A . 3 - VD0  
 :  
 - VD1  
 Divider system      Version      n<sub>T</sub>      Height separation

Please state the designation of the divider system (TS0, TS1,...), the version, and the number of dividers per cross section [n<sub>T</sub>].

When using divider systems with height separation (TS1), please additionally state the position (e.g. VD1) viewed from the left driver belt. You are welcome to add a sketch to your order.



### TRAXLINE® cables for cable carriers

Hi-flex electric cables which were specially developed, optimised and tested for use in cable carriers can be found at [tsubaki-kabelschlepp.com/traxline](http://tsubaki-kabelschlepp.com/traxline).

## Single-part end connectors – plastic (with integrated strain relief)

The plastic end connectors can be connected from above or below. The connection type can be changed by altering the position of the end connector.

Driver

Fixed point

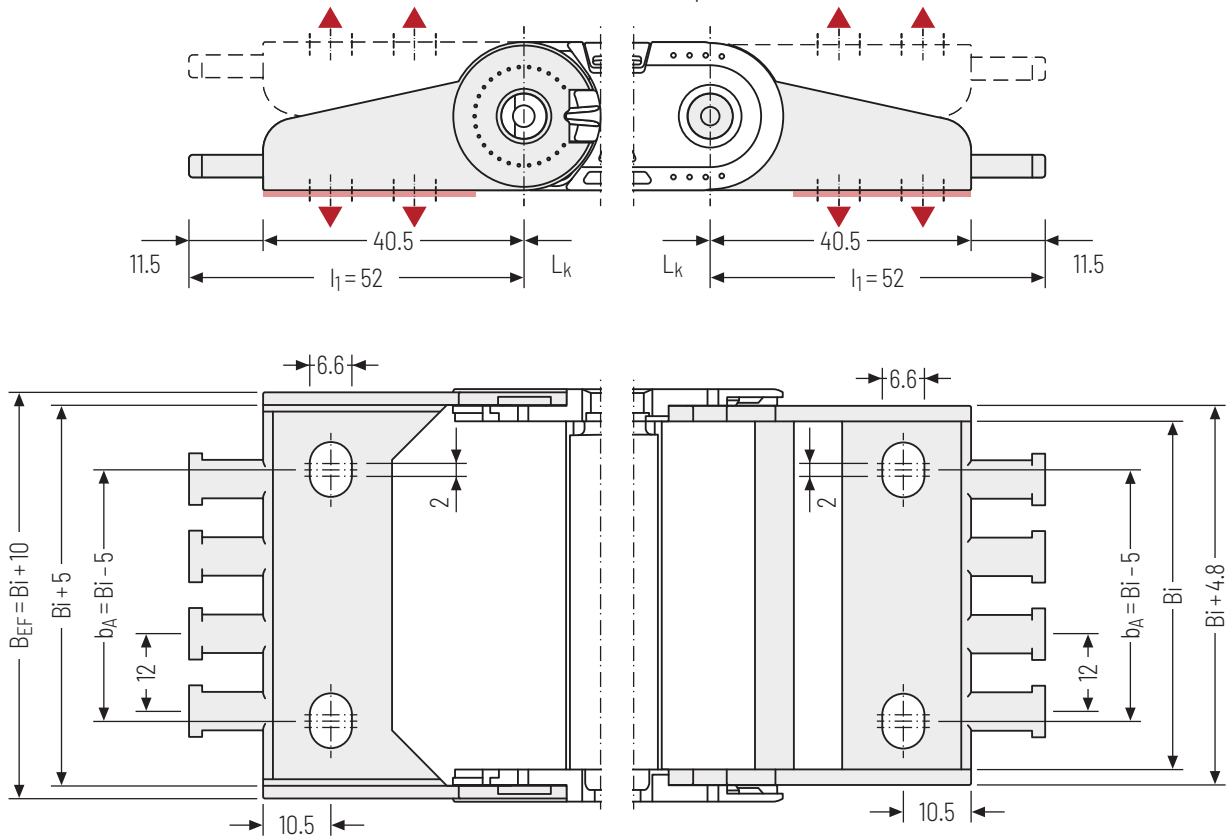

### ▲ Assembly options

$B_i$ [mm]	$B_{EF}$ [mm]	$n_z$
30	40	2
50	60	4

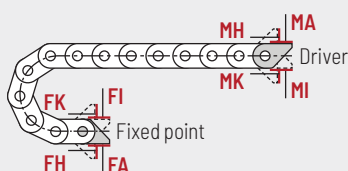

### Connection point

- F** - fixed point
- M** - driver

### Connection type

- A** - threaded joint outside (standard)
- I** - threaded joint inside
- H** - threaded joint, rotated 90° to the outside
- K** - threaded joint, rotated 90° to the inside

### Order example



Cable carrier

Cable carrier configuration

Configuration guidelines

Materials information

MONO series

QuickTrax® series

UNIFLEX Advanced series

TKP35 series

TKK series

EasyTrax® series

# QT0320

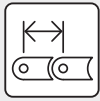

**Pitch**  
32 mm

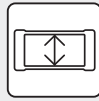

**Inner height**  
20 mm

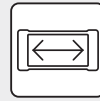

**Inner widths**  
15 - 65 mm

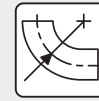

**Bending radii**  
28 - 125 mm

## Stay variants



**Design 030** ..... page **140**

### Frame with outside opening crossbars

- » Weight-optimised plastic frame with particularly high torsional rigidity.
- » Crossbar can be opened at any position on one side.
- » **Outside:** openable.



**Design 040** ..... page **141**

### Frame with inside opening crossbars

- » Weight-optimised plastic frame with particularly high torsional rigidity.
- » Crossbar can be opened at any position on one side.
- » **Inside:** openable.

Cable carrier

Cable carrier  
configurationConfiguration  
guidelinesMaterials  
informationMONO  
seriesQuickTrax®  
seriesUNIFLEX  
Advanced  
seriesTKP35  
seriesTKK  
seriesEasyTrax®  
series

### Unsupported arrangement

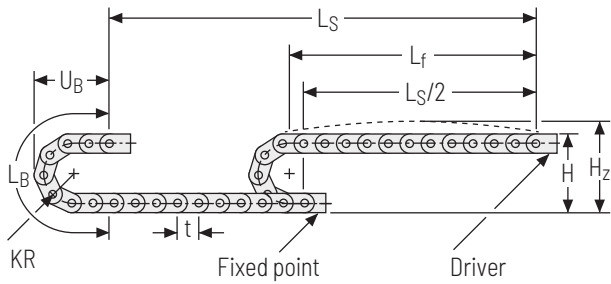

KR [mm]	H [mm]	H <sub>z</sub> [mm]	L <sub>B</sub> [mm]	U <sub>B</sub> [mm]
28	81.5	101.5	152	73
38	101.5	121.5	184	83
48	121.5	141.5	215	93
75	175.5	195.5	300	120
100	225.5	245.5	379	145
125	275.5	295.5	457	170

### Load diagram for unsupported length

depending on the additional load.

Intrinsic cable carrier weight  $q_k = 0.40 \text{ kg/m}$  with  $B_i$  38 mm. For other inner widths, the maximum additional load changes.

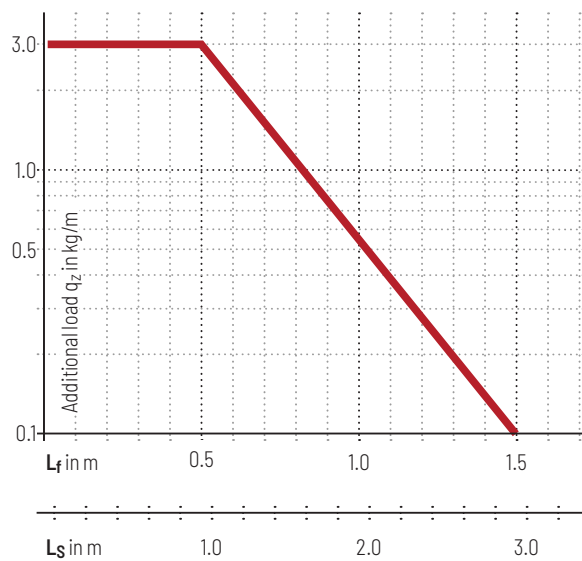

**Speed**  
up to 10 m/s

**Acceleration**  
up to  $50 \text{ m/s}^2$

**Travel length**  
up to 2.9 m

**Additional load**  
up to  $3 \text{ kg/m}$

### Gliding arrangement

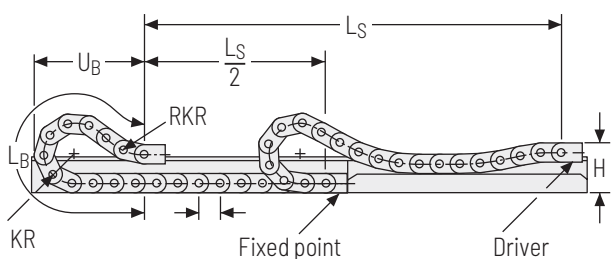

**Speed**  
up to 2.5 m/s

**Acceleration**  
up to  $25 \text{ m/s}^2$

**Travel length**  
up to 80 m

**Additional load**  
up to  $3 \text{ kg/m}$

The gliding cable carrier must be guided in a channel. See p. 850.

Only design 030 can be used for a gliding arrangement.

Cable carrier
Cable carrier configuration
Configuration guidelines
Materials information
MONO series
<b>QuickTrax® series</b>
UNIFLEX Advanced series
TKP35 series
TKK series
EasyTrax® series

### Stay variant 030 – with outside opening crossbars

- » Weight-optimised plastic frame with particularly high torsional rigidity.
- » Crossbars can be opened at any position on one side
- » **Outside:** openable.



Stay arrangement on each chain link (**VS: fully-stayed**)



$B_i$  15 – 65 mm

Cable carrier

Cable carrier configuration

Configuration guidelines

Materials information

MONO series

QuickTrax® series

UNIFLEX Advanced series

TKP35 series

TKK series

EasyTrax® series

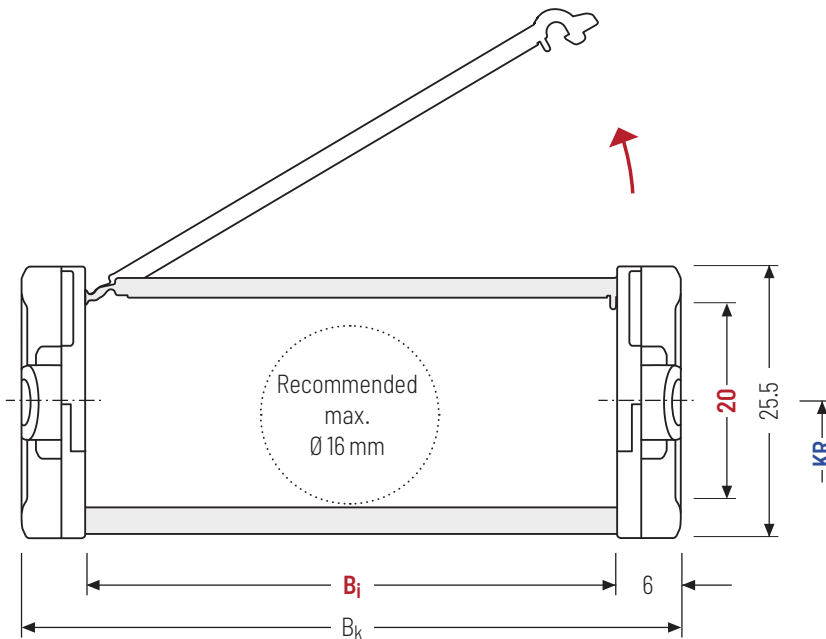

The maximum cable diameter strongly depends on the bending radius and the desired cable type. Please contact us.

#### Calculating the cable carrier length

##### Cable carrier length $L_k$

$$L_k \approx \frac{L_S}{2} + L_B$$

Cable carrier length  $L_k$  rounded to pitch  $t$

$h_i$ [mm]	$h_G$ [mm]	$B_i$ [mm]					$B_k$ [mm]	KR [mm]					$q_k$ [kg/m]	
20	25.5	15	25	38	50	65	$B_i + 12$	28	38	48	75	100	125	0.35 – 0.45

#### Order example

QT0320
Type
·
030
Stay variant
·
50
 $B_i$  [mm]
·
100
KR [mm]
-
1,280
 $L_k$  [mm]
-
VS
Stay arrangement

## Stay variant 040 - with inside opening crossbars

- » Weight-optimised plastic frame with particularly high torsional rigidity.
- » Crossbars can be opened at any position on one side
- » **Inside:** openable.



Stay arrangement on each chain link (VS: fully-stayed)



$B_i$  15 - 65 mm

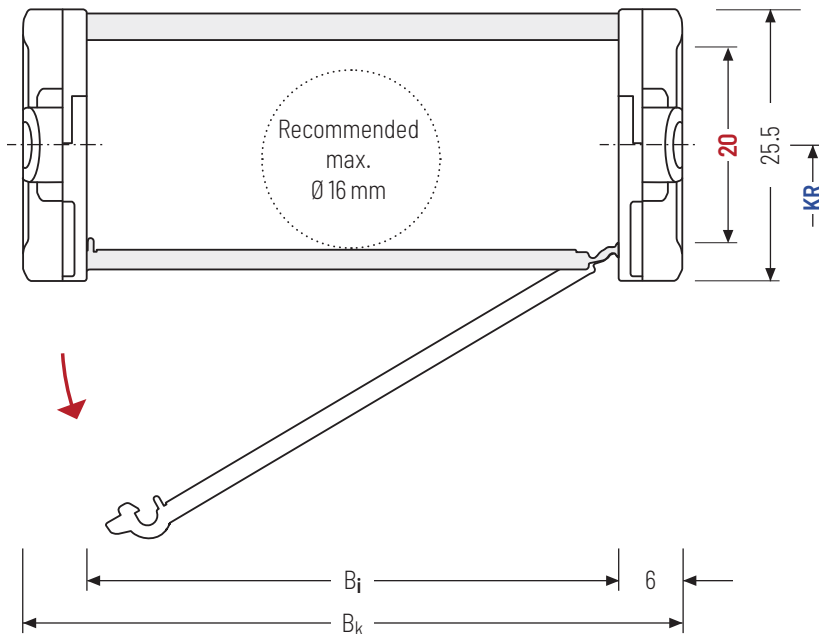

The maximum cable diameter strongly depends on the bending radius and the desired cable type. Please contact us.

### Calculating the cable carrier length

#### Cable carrier length $L_k$

$$L_k \approx \frac{L_S}{2} + L_B$$

Cable carrier length  $L_k$  rounded to pitch  $t$

$h_i$ [mm]	$h_G$ [mm]	$B_i$ [mm]						$B_k$ [mm]	$KR$ [mm]						$q_k$ [kg/m]
20	25.5	15	25	38	50	65	$B_i + 12$	28	38	48	75	100	125	0.35 - 0.45	

### Order example

QT0320 Type · 
 040 Stay variant · 
 50  $B_i$  [mm] · 
 100  $KR$  [mm] · 
 1,280  $L_k$  [mm] · 
 VS Stay arrangement



### Divider systems

The divider system is mounted on each crossbar as a standard – on every 2<sup>nd</sup> chain link for stay mounting (HS).

As a standard, dividers or the complete divider system (dividers with height separations) are movable in the cross section (**version A**).

#### Divider system TSO without height separation

Vers.	a <sub>T</sub> min [mm]	a <sub>x</sub> min [mm]	a <sub>c</sub> min [mm]	n <sub>T</sub> min
A	4	8	6	-

The dividers can be moved in the cross section.

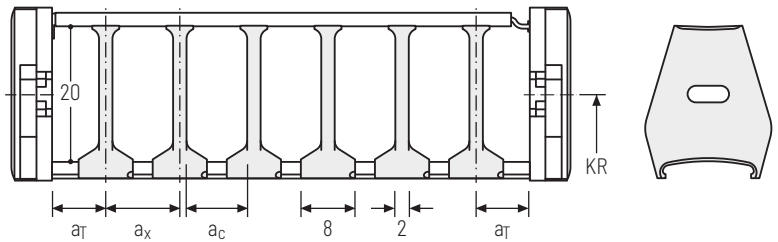

#### Divider system TS1 with continuous height separation

Vers.	a <sub>T</sub> min [mm]	a <sub>x</sub> min [mm]	a <sub>c</sub> min [mm]	n <sub>T</sub> min
A	4	8	6	2

The dividers can be moved in the cross section.

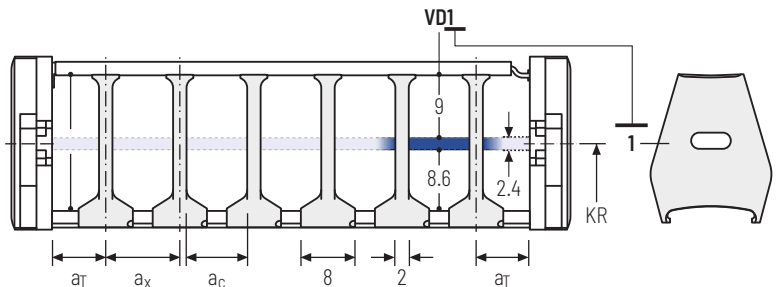

#### Order example

TS1	·	A	·	3	-	VD0
⋮						
						VD1
Divider system		Version		n <sub>T</sub>		Height separation

Please state the designation of the divider system (TS0, TS1,...), the version, and the number of dividers per cross section [n<sub>T</sub>].

When using divider systems with height separation (TS1), please additionally state the position (e.g. VD1) viewed from the left driver belt. You are welcome to add a sketch to your order.



#### TRAXLINE® cables for cable carriers

Hi-flex electric cables which were specially developed, optimised and tested for use in cable carriers can be found at [tsubaki-kabelschlepp.com/traxline](http://tsubaki-kabelschlepp.com/traxline).

## Single-part end connectors – plastic (with integrated strain relief)

The plastic end connectors can be connected from above or below. The connection type can be changed by altering the position of the end connector.

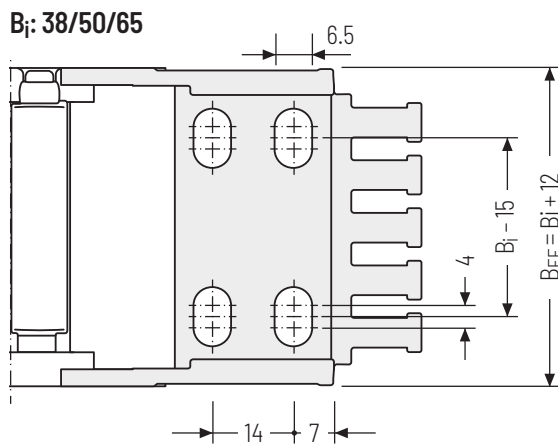
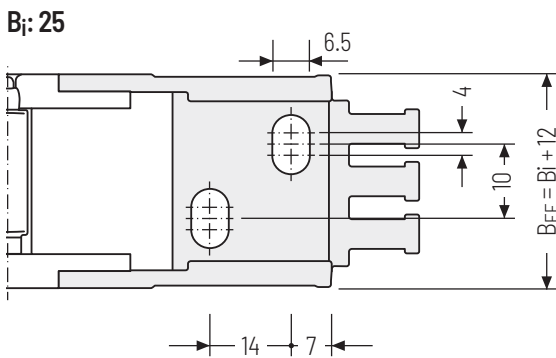
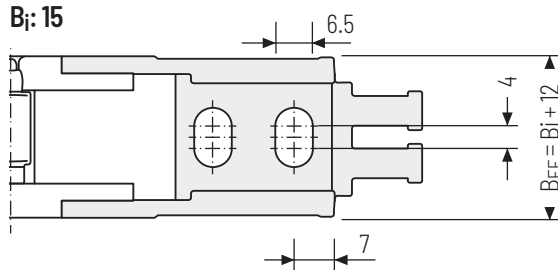
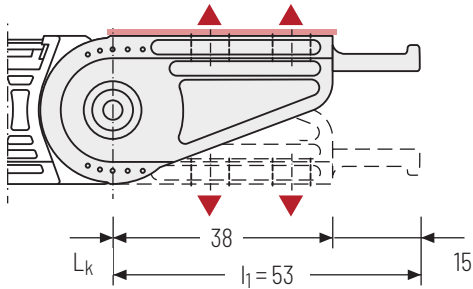

### ▲ Assembly options

$B_i$ [mm]	$B_{EF}$ [mm]	$n_z$
15	27	2
25	37	3
38	50	4
50	62	5
65	77	6

 The end connectors can not be swivelled.

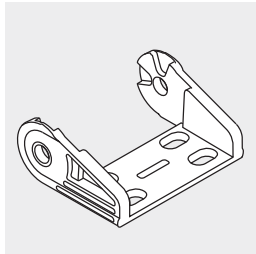

The end connectors are also available as an option **without** integrated strain relief. Please state when ordering.

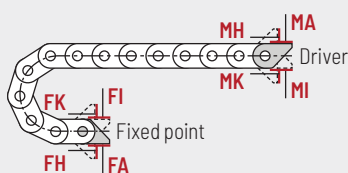

### Connection point

- F** - fixed point
- M** - driver

### Connection type

- A** - threaded joint outside (standard)
- I** - threaded joint inside
- H** - threaded joint, rotated 90° to the outside
- K** - threaded joint, rotated 90° to the inside

### Order example



End connector

F

A

End connector

M

A

Connection point    Connection type