

TKK series

Dirt-repellent cable carriers
made of plastic



Trademarks are legally protected for TSUBAKI KABELSCHLEPP GmbH as a national or international registration in the following countries: [tsubaki-kabelschlepp.com/trademarks](https://www.tsubaki-kabelschlepp.com/trademarks)

Subject to change without notice.



- 1 Very short steel end connectors
- 2 Plastic chain links
- 3 Extensive unsupported length
- 4 Link system repels dust and chips
- 5 Smooth surface for smooth running
- 6 Inside openable (design 040)
- 7 Dividers and height separations for cable separation

Features

- » High torsional rigidity
- » Optimised dividers to protect cables: rounded inner and outer profile
- » Extensive unsupported length
- » New dirt-resistant design of the chain links to protect against dust and chips
- » Smooth surface for optimum running
- » Closed and openable designs
- » Very short end connectors
- » Fixable dividers
- » Optimised stroke system
- » High side stability
- » Space-saving design for small spaces

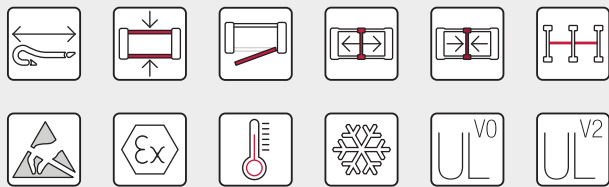

Optimised divider design to protect cables



New design of chain links. Link system repels dust, chips and dirt

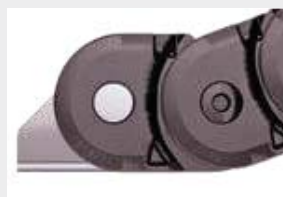

Very short end connectors

Subject to change without notice.

Cable carrier
Cable carrier configuration
Configuration guidelines
Materials information
MONO series
QuickTrax® series
UNIFLEX Advanced series
TKP35 series
TKK series
EasyTrax® series

TKK series | Overview

Cable carrier	Cable carrier configuration	Configuration guidelines	Materials information	MONO series	QuickTrax® series	UNIFLEX Advanced series	TKP35 series	TKK series	EasyTrax® series
---------------	-----------------------------	--------------------------	-----------------------	-------------	-------------------	-------------------------	--------------	-------------------	------------------

Type	Opening variant	Stay variant	h_i [mm]	h_G [mm]	B_i [mm]	B_k [mm]	B_i - grid [mm]	t [mm]	KR [mm]	Additional load \leq [kg/m]	Cable- d_{max} [mm]
------	-----------------	--------------	---------------	---------------	---------------	---------------	-------------------------	-------------	------------	-------------------------------------	-----------------------------

TKK39



	020	39	50	39-99	60-120	-	39	46-95	10	31
	040	39	50	39-99	60-120	-	39	46-95	10	31

Unsupported arrangement			Gliding arrangement			Inner Distribution				Movement			Page
Travel length ≤ [m]	v_{max} ≤ [m/s]	a_{max} ≤ [m/s ²]	Travel length ≤ [m]	v_{max} ≤ [m/s]	a_{max} ≤ [m/s ²]	TS0	TS1	TS2	TS3	vertical hanging or standing	lying on the side	rotating arrangement	
										•	•	•	228
4.8	3	9	120	2.5	9	•	•	-	-	•	•	•	228
4.8	3	9	-	-	-	•	•	-	-	•	•	•	229

Cable carrier

Cable carrier configuration

Configuration guidelines

Materials information

MONO series

QuickTrax® series

UNIFLEX Advanced series

TKP35 series

TKK series

EasyTrax® series

TKK39

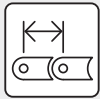

Pitch
39 mm



Inner height
39 mm

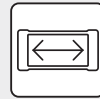

Inner width
39 – 99 mm



Bending radii
46 – 95 mm

Stay variants



Design 020 page **228**

Closed frame

- » Weight-optimised, closed plastic frame with particularly high torsional rigidity.
- » **Outside/inside:** closed.



Design 040 page **229**

Frame with inside opening crossbar

- » Weight-optimised plastic frame with particularly high torsional rigidity.
- » Crossbars can be opened at any position on one side.
- » **Inside:** openable.



TRAXLINE® cables for cable carriers

Hi-flex electric cables which were specially developed, optimised and tested for use in cable carriers can be found at tsubaki-kabelschlepp.com/traxline.

Additional product information online



Installation instructions, etc.:
Additional information via your smartphone or online at tsubaki-kabelschlepp.com/downloads



Configure your cable carrier here:
online-engineer.de

Unsupported arrangement

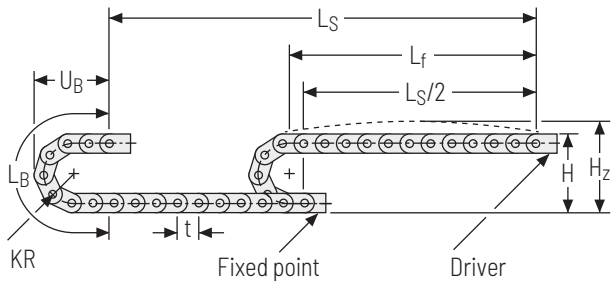

KR [mm]	H [mm]	H _z [mm]	L _B [mm]	U _B [mm]
46	142	172	222	149
58	166	196	260	161
70	190	220	298	173
95	240	270	376	198

Load diagram for unsupported length depending on the additional load.

Sagging of the cable carrier is technically permitted for extended travel lengths, depending on the specific application.

Intrinsic cable carrier weight $q_k = 1.56 \text{ kg/m}$. The maximum additional load changes with deviating inner widths.

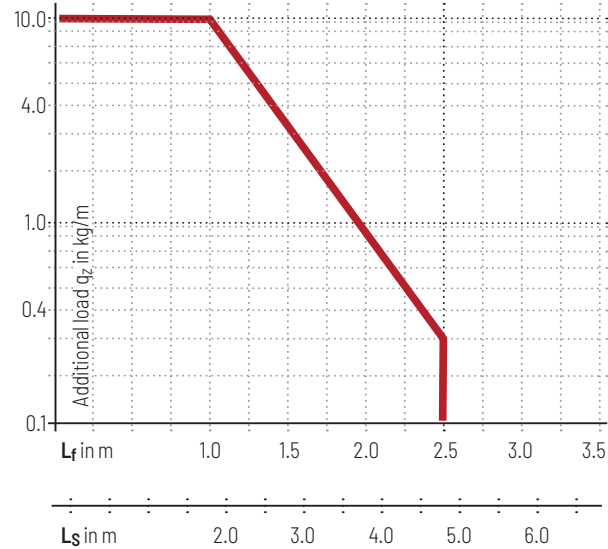

Speed
up to 3 m/s

Acceleration
up to 9 m/s^2

Travel length
up to 4.8 m

Additional load
up to 10 kg/m

Gliding arrangement

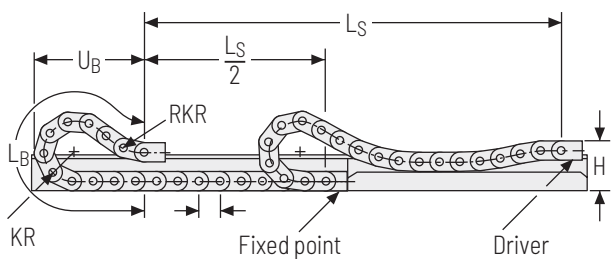

KR [mm]	H [mm]	n _{RKR}	L _B [mm]	U _B [mm]
46	142	0	222	149
58	150	2	405	196
70	150	3	551	257
95	150	4	770	341

Speed
up to 2.5 m/s

Acceleration
up to 9 m/s^2

Travel length
up to 120 m

Additional load
up to 10 kg/m

 The gliding cable carrier must be guided in a channel. See p. 850.

Glide shoes must be used for gliding applications.

Only design 020 can be used for a gliding arrangement.

Stay variant 020 - closed frame

- » Weight-optimised, closed plastic frame with particularly high torsional rigidity.
- » **Outside/inside:** closed.



Stay arrangement on each chain link (**VS: fully-stayed**)



B_i 39 - 99 mm

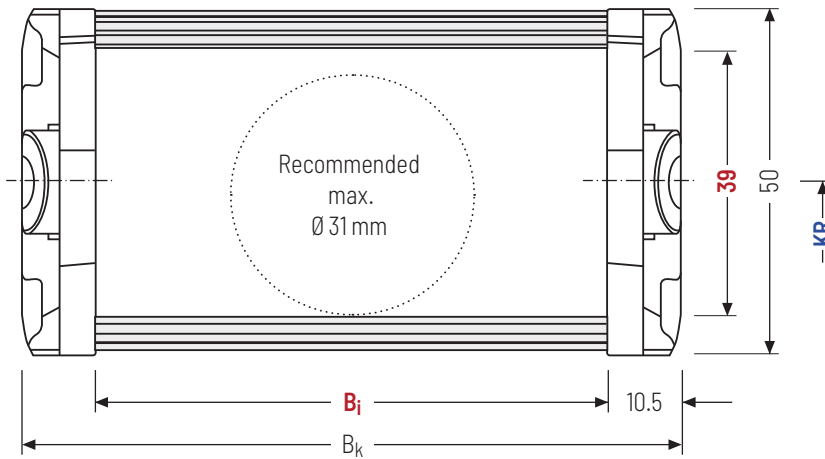

The maximum cable diameter strongly depends on the bending radius and the desired cable type. Please contact us.

Calculating the cable carrier length

Cable carrier length L_k

$$L_k \approx \frac{L_S}{2} + L_B$$

Cable carrier length L_k rounded to pitch t

h_i [mm]	h_g [mm]	B_i [mm]				B_k [mm]	KR [mm]				q_k [kg/m]
39	50	39	59	74	99	$B_i + 21$	46	58	70	95	1.29 - 1.71

Order example

TKK39
·
020
·
74
·
70
-
1950
·
VS

Type Stay variant B_i [mm] KR [mm] L_k [mm] Stay arrangement

Stay variant 040 - with inside opening crossbar

- » Weight-optimised plastic frame with particularly high torsional rigidity.
- » Crossbars can be opened at any position on one side.
- » **Inside:** openable.



Stay arrangement on each chain link (VS: fully-stayed)



B_i 39 - 99 mm

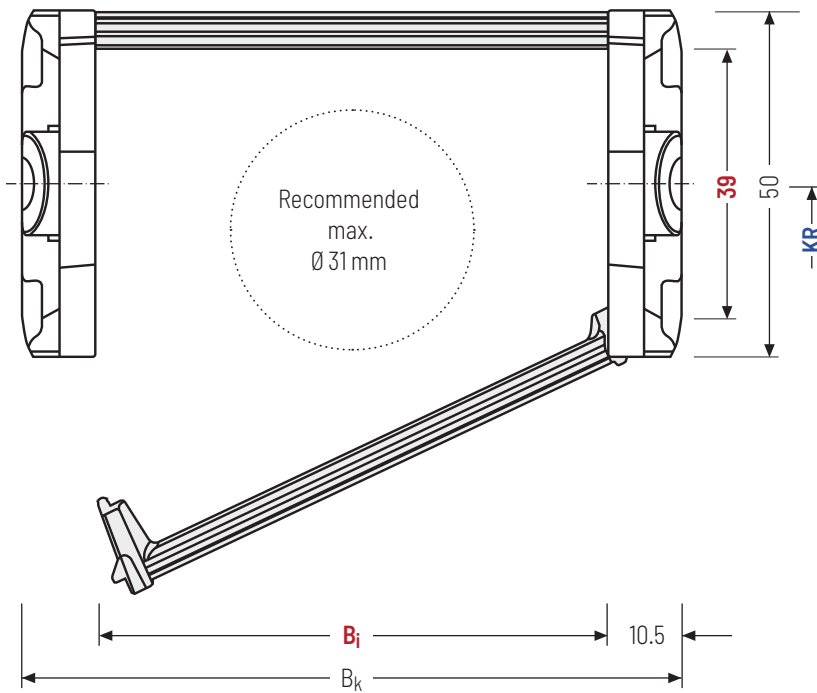

The maximum cable diameter strongly depends on the bending radius and the desired cable type. Please contact us.

Calculating the cable carrier length

Cable carrier length L_k

$$L_k \approx \frac{L_S}{2} + L_B$$

Cable carrier length L_k rounded to pitch t

h_i [mm]	h_g [mm]	B_i [mm]				B_k [mm]	KR [mm]				q_k [kg/m]
39	50	39	59	74	99	$B_i + 21$	46	58	70	95	1.29 - 1.72

Order example



TKK39 Type	·	040 Stay variant	·	74 B_i [mm]	·	70 KR [mm]	-	1950 L_k [mm]		VS Stay arrangement
----------------------	---	----------------------------	---	-------------------------	---	------------------------	---	---------------------------	--	-------------------------------

Divider systems

The divider system is mounted on every 2nd chain link as a standard.

For applications with lateral accelerations and applications with the cable carrier rotated by 90°, the dividers can easily be fixed on the stay.

Dividers, and the complete divider system (dividers with height separations) comes as diameter adjustable as standard (**version A**).

The arresting cams snap into the catch profiles in the crossbars (**version B**).

Divider system TSO without height separation

Vers.	a _T min [mm]	a _x min [mm]	a _c min [mm]	a _x grid [mm]	η _T min
A	5	10	7	-	-
B*	9.5	10	7	2	-

* not for design 020

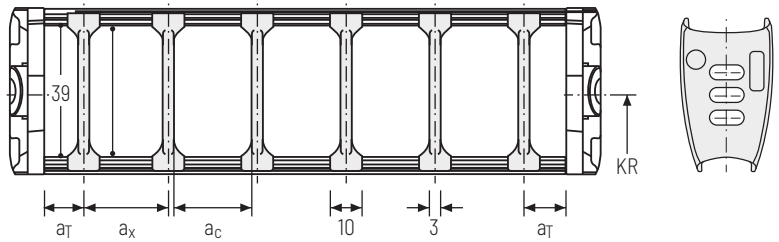

The dividers can be moved in the cross section.

Divider system TS1 with continuous height separation*

Vers.	a _T min [mm]	a _x min [mm]	a _c min [mm]	a _x grid [mm]	η _T min
A	5	10	7	-	2
B	9.5	10	7	2	2

* not for design 020

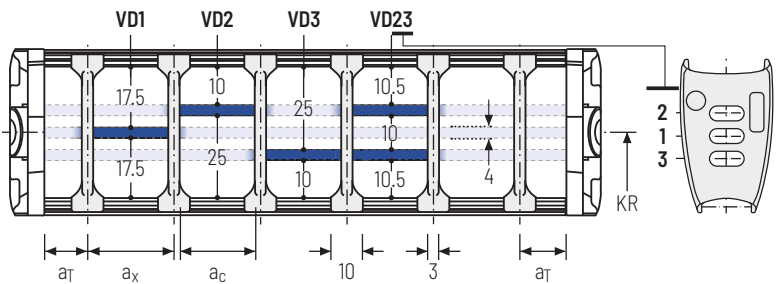

The dividers can be moved in the cross section.

Order example

TS1

A

3

- VD1

⋮

- VD3

Divider system

Version

η_T

Height separation

Please state the designation of the divider system (**TS0, TS1,...**), the version, and the number of dividers per cross section [η_T].

When using divider systems with height separation (**TS1**), please additionally state the position (e.g. VD1) viewed from the left driver belt. You are welcome to add a sketch to your order.

End connectors – steel

The steel end connectors can be connected **from above or below**. The connection type can be changed by altering the position of the end connector.

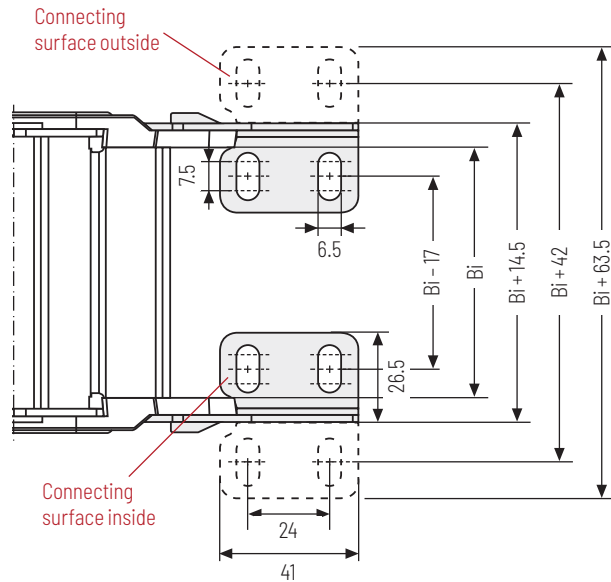
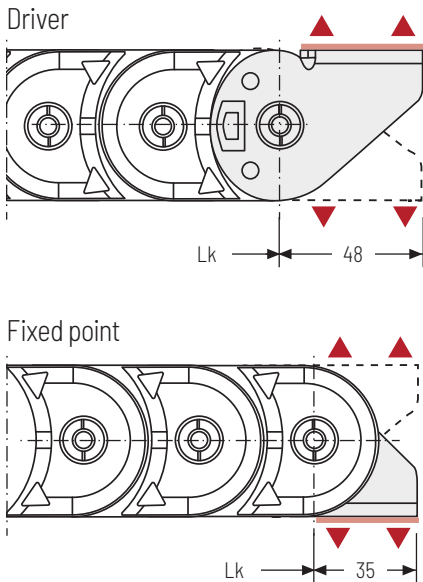

▲ Assembly options

Connection point

- F** – fixed point
- M** – driver

Connection type

- A** – connecting surface outside
- I** – connecting surface inside

Connecting surface

- A** – threaded joint outside (standard)
- I** – threaded joint inside

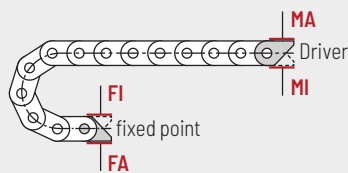

Order example

	Steel	F	A	I
	Steel	M	A	I
	End connector	Connection point	Connection type	Connecting surface



We recommend the use of strain reliefs at the driver and fixed point. See from p. 908.

Additional product information online



Installation instructions, etc.:
Additional info via your smartphone or check online at tsubaki-kabelschlepp.com/downloads



Configure your cable carrier here:
online-engineer.de